

These guidelines for captive management are a collective project of the Jaguar SSP Management Group. Their purpose is to provide a general guide to zoo professionals for proper care of the species. The manual should also serve as a reference tool from natural history to *in situ* and *ex situ* research information. We hope to distinguish the jaguar's physiological and psychological needs from other big cats for proper care of the species.

Jaguar SSP

Species Coordinator, Bob Wiese, Fort Worth Zoo; bob@fortworthzoo.org

Management Group

Steven Marks	Elmwood Park Zoo	smarks@elmwoodparkzoo.com
Daniel Morris	Omaha's Henry Doorly Zoo	djmhdz@aol.com
Alan Rost	Jacksonville Zoological Gardens	rosta@jaxzoo.org
Jim Schnormeier	Sacramento Zoo	jrs@saczoo.com
Jerry Stones	Gladys Porter Zoo	jstones@gpz.org
Diana Weinhardt	Houston Zoo	beartagsow@aol.com
R. Leslie Whitt	Alexandria Zoo	Les.Whitt@cityofalex.com

Advisors

Cheri Asa	St. Louis Zoo (Meso-America CAP)	asa@slu.edu
Sharon Deem	Smithsonian National Zoo (Health)	deems@nzp.si.edu
Mike Fouraker	Fort Worth Zoo (Husbandry)	mfouraker@fortworthzoo.org
Jack Grisham	(Husbandry)	jmgcheta@aol.com
Stacey Johnson	Fort Worth Zoo (Education)	sjohnson@fortworthzoo.org
Rebecca Spindler	Smithsonian National Zoo (Repro.)	rspindler@crc.si.edu
Ann Ward	Fort Worth Zoo (Nutrition)	award@fortworthzoo.org

Jaguar Species Survival Plan
**GUIDELINES FOR CAPTIVE MANAGEMENT OF
 JAGUARS**

Christopher Law, Elmwood Park Zoo, Editor

William K. Baker, Jr., Little Rock Zoo; Sharon Deem DVM, National Zoological Park; Amy Hunt,
 MS, Fort Worth Zoo; Linda Munson DVM, University of California; Stacey Johnson, Fort Worth Zoo;
 Rebecca Spindler, Ph.D., National Zoological Park; Ann Ward, MS, Fort Worth Zoo, Contributors.

Table of Contents

DESCRIPTION	3
DISTRIBUTION	3
STATUS	4
TAXONOMY	5
NATURAL HISTORY and BEHAVIOR	8
CAPTIVE MANAGEMENT	17
TRANSPORT	24
REPRODUCTION	28
REPRODUCTIVE DISEASES	38
ENVIRONMENTAL ENRICHMENT	48
NUTRITION	55
HAND-REARING	62
HEALTH CARE	75
BIBLIOGRAPHY	90

Description, Distribution, Status and Taxonomy

Stacey Johnson, Fort Worth Zoo

DESCRIPTION

The jaguar is the largest cat in the Americas, with a record weight of over 158 kilograms (Emmons, 1997). The largest jaguars have been found in the Brazilian Pantanal region, where in one study the average weight of males was 100 kilograms. Head and body length, without the tail may be up to six feet (1.85meters), and the tail can measure 75 centimeters more. Height at the shoulder may be up to 75 centimeters (Nowak and Paradiso, 1983).

The jaguar's coat color ranges from pale yellow to reddish brown, with a much paler (often white) underbelly. It has spots on the neck, body and limbs that form rosettes, which contain black markings within them. On the head and underparts, the spots are simple black dots. Black jaguars are not uncommon, and even they possess darker rosette markings that are visible in bright light. Black jaguars are recognized as a color morph of the same species.

Compared to a leopard, the jaguar is stocky and more powerfully built. The square jaw and prominent cheeks, along with robust, muscular limbs give evidence of immense strength. It has been said that the jaguar is built for power, not speed. While true, this cat also demonstrates surprising stealth and grace in movement.

DISTRIBUTION

First appearing in the fossil record around 2 million years ago, the jaguar has been an American species at least that long (Turner, 1997). Found throughout what is now the southern United States until about 10,000 years ago, it was eliminated from the US around 1900 (Nowak and Paradiso, 1983). In the late 1990s, several sightings in Arizona occurred, prompting renewed interest in the jaguar's northernmost habitat and distribution. The southern edge of its range is now northern Argentina, but once extended into Uruguay.

Range countries: Argentina, Belize, Bolivia, Brazil, Colombia, Costa Rica, Ecuador, French Guiana, Guatemala, Guyana, Honduras, Mexico, Nicaragua, Panama, Paraguay, Peru, Suriname, United States, Venezuela. The jaguar is now extinct in El Salvador and Uruguay (IUCN, 2000).

Habitat is variable for the species. It is found from lowland jungle to montane forest and at altitudes of up to 2,000 meters (6,500 feet) as well as wet grassland and arid scrub. A preference for water seems evident. The jaguar is an excellent swimmer, and has also been known to patrol ocean beaches preying on buried sea turtle eggs.

Major habitats include grassland, lowland tropical rainforest, montane tropical rainforest, succulent and thorn scrub, temperate broadleaf forest, tropical monsoon and dry forest, tropical savannah woodland (Emmons, 1997).

PROTECTION AND POPULATION STATUS

The jaguar is regulated as an Appendix I species under CITES (Convention on International Trade in Endangered Species). This means that all international trade in jaguars or their parts is prohibited.

The International Union for the Conservation of Nature (IUCN) lists jaguars as Lower Risk, Near-Threatened.

The US Endangered Species Act protects jaguars as Endangered.

Major threats to the species are population fragmentation, deforestation and direct persecution.

Overall the trend in population is a decline.

Any hunting of jaguars is prohibited in Argentina, Colombia, French Guiana, Honduras, Nicaragua, Panama, Paraguay, Suriname, United States, Uruguay and Venezuela.

Hunting of jaguars is restricted to “problem animals” in Brazil, Costa Rica, Guatemala, Mexico and Peru.

Trophy hunting is permitted in Bolivia.

The species has no legal protection in Ecuador or Guyana (IUCN, 2000).

Central American populations

In 1991, Rabinowitz estimated a jaguar population in Belize of 600 to 1000 animals.

Aranda estimated in 1990 that 125-180 jaguars were living in Mexico’s 4,000 km² (2,400 mi²) Calakmul Biosphere Reserve, and additional 465-550 animals in the adjoining Maya Biosphere Reserve in Guatemala, an area measuring 15,000 km² (9,000 mi²).

The same researcher has also estimated that some 350 jaguars may be living in several areas of Chiapas state, Mexico.

South American populations

The Pantanal is a seasonally flooded wetland covering more than 100,000 km² (60,000 mi²) in Brazil, Bolivia and Paraguay. A rough population density estimate by Quigley and Crawshaw, in 1992, of 1.4 resident adults per 100 km² means that about 1,400 jaguars may exist in that area.

Population estimates in the Amazon Basin and Orinoco Basin vary, and are difficult to obtain. In some regions, jaguars are said to be very common while in others the species has disappeared completely.

Overall, it seems that jaguars are not in immediate peril of extinction. However, their current geographic range is somewhere between one-third and half its historical size (IUCN, www.lynx.uio.no/catfolk/onca-01.htm).

TAXONOMY

The jaguar is the only American member of the genus *Panthera* (Family Felidae, Class Mammalia). Aside from being generally larger than all other cats, *Panthera* species have an incompletely ossified hyoid apparatus that allows the vocalization known as roaring, but restricts purring to exhalation.

Traditional taxonomic methods, relying on morphology and geography divided the family Felidae into four genera (*Acinonyx*, *Felis*, *Neofelis* and *Panthera*) (Nowak and Paradiso, 1983) but work in molecular genetics has brought to light a much more complicated relationship among groups of cats. Three major groups, the ocelot lineage, the domestic cat lineage and the pantherine lineage have been recognized and include more than a dozen genera (Johnson and O'Brien, 1997). As a species, the jaguar fits easily into both traditional taxonomy and current molecular systematics. However, at the subspecies level its status is much less clear. This section outlines the history and current taxonomic placement of *Panthera onca* across its range.

Culminating with the tenth edition of Linnaeus' *Systema Naturae* in 1758, classification of living organisms was based on physical characteristics and on the geographic location in which type specimens originated. This work used a downward classification scheme whereby large groups were split into smaller groups based on possession or lack of a characteristic. Identification keys, consistent and specific descriptions and standardization of synonymous names – and, of course, binomial nomenclature – were the tools that set *Systema Naturae* apart from its predecessors (Mayr and Ashlock, 1991). It defined the standard for taxonomic method for two centuries. Until the mid-Twentieth Century, organisms were classified according to similarities and differences making no direct implication of actual genetic relatedness.

After Watson and Crick deduced the structure of DNA and its role as the genetic blueprint biologists began to classify organisms based on their genetic relationships and their places in ecosystems. Today, researchers in biosystematics focus much of their work on phylogenetic relationships among species. In addition to physical characteristics, they use a number of techniques at the molecular level, seeking to understand how organisms are genetically connected to one another and to construct family trees that demonstrate the relationships. Systematists take into account geographic, genetic, behavioral, chronological and other circumstances that may have served as isolating mechanisms to create new species over time.

From mitochondrial DNA (mtDNA) evidence, it appears the jaguar shared its last common ancestor with other big cats (lion, tiger, leopard and snow leopard) six million years ago. However, current fossil evidence suggests the genus *Panthera* arose only in the last two to three million years. Morphological similarities imply a monophyletic origin among lions, tigers, leopards and jaguars; yet specific relationships based on mtDNA have evaded clear definition and may lean toward a polyphyletic (*i.e.* from multiple ancestral sources) radiation (Johnson and O'Brien, 1997). The last taxonomic revision of *Panthera onca* into subspecies was published in 1939 (Pocock, 1939). Pocock measured skull characters and grouped specimens according to their collection localities, revising the number of species and races of jaguar downward from 24 to eight, as follows:

<i>Nomenclature</i>	<i>Taxonomist</i>	<i>Described</i>	<i>Geographic range</i>
<i>P. onca onca</i>	Linnaeus	1758	Venezuela, south and east to Rio Grande do Sul in Brazil
<i>P. onca palustris</i>	Ameghino	1888	Matto Grosso, Paraguay and northeastern Argentina
<i>P. onca peruviana</i>	Blainville	1843	Coastal Peru
<i>P. onca centralis</i>	Mearns	1901	Central America – El Salvador to Colombia
<i>P. onca hernandesii</i>	Gray	1857	Western Mexico
<i>P. onca arizonensis</i>	Goldman	1932	Eastern Arizona to Sonora, Mexico
<i>P. onca veraecrucis</i>	Nelson and Goldman	1933	Southeastern Mexico to central Texas
<i>P. onca goldmani</i>	Mearns	1901	Yucatan peninsula to Guatemala and Belize

However, he concluded that individual variation among specimens outweighed any true systematic differentiation; and his subspecies were based only on the geographic origins of the study skulls at the British Museum.

Larson's 1997 re-evaluation of jaguar subspecific taxonomy began with Pocock's revision based on skull morphology and then applied the same criteria and statistical analysis to a different study set of 170 skulls of known geographic origin. Her study concluded that clinal variation exists from north to south, but emphasized that there is more variation within subspecies than between subspecies (Larson, 1997). While skull morphology is by no means the only criterion on which to base jaguar taxonomy it was, and continues to be, a primary method used alongside molecular genetics techniques.

An analysis, published in 2001, of mtDNA differences and microsatellite location in somatic DNA reveals very weak phylogeographic differentiation. It indicates that jaguars from the southern part of the range are significantly different from those in the northern part of the range. A much less marked difference appears between populations living Central America and those from northern South America. The Amazon River and the former Darien Straits, between what is now Panama and Colombia, were posed as geographic isolators. A comparison with similar studies in other species suggested that as a species, jaguars might be in an expansion and rapid growth phase of habitat exploitation. Under such conditions, along with the counter-pressures of habitat fragmentation and persecution, broad genetic diversity without deep geographic differentiation could be expected. While the paper recommends avoiding across-range management of the species in the wild, it also suggests the need for a revision of its taxonomy at the subspecies level (Eizirik, *et al.*, 2001). For the purposes of captive management and public education, the Jaguar Species Survival Plan considers *Panthera onca* a single species without subspecific designation.

REFERENCES

- Emmons, Louise H. 1997. *Neotropical Rainforest Mammals*. 2nd Edition. Chicago: University of Chicago Press. p 168-9.
- Nowak, R., and J. Paradiso, eds. 1983. *Walker's Mammals of the World*. 4th Edition. Baltimore: Johns Hopkins University Press. p 1091-2
- Turner, Alan. 1997. *Big Cats and Their Fossil Relatives*. New York: Columbia University Press.
- International Union for the Conservation of Nature (IUCN). 2000. *2000 IUCN Redlist of Threatened Species*. Gland: IUCN.
- International Union for the Conservation of Nature, Cat Specialist Group.*
Website: <http://www lynx.uio.no/catfolk/onca-01.htm>
- Johnson, Warren E., and S. J. O'Brien. 1997. Phylogenetic Reconstruction of the Felidae Using 16S rRNA and NADH-H Mitochondrial Genes. *J. Mol. Evol.* 44:98-116.
- Mayr, Ernst and P. Ashlock. 1991. *Principles of Systematic Zoology*. 2nd Edition. New York: McGraw-Hill, Inc. p 9.
- Pocock, R. I. 1939. The Races of Jaguar (*Panthera onca*). *Novitates Zoologicae*. Volume XLI. p 406-422.
- Larson, Shawn E. 1997. Taxonomic Re-Evaluation of the Jaguar. *Zoo Biol.* 16:107-120.
- Eizirik, Eduardo, Jae-Heup Kim, Marilyn Menotti-Raymond, Peter G. Crawshaw Jr., Stephen J. O'Brien, and Warren E. Johnson. 2001. Phylogeography, Population History and Conservation of Jaguars (*Panthera onca*, Mammalia, Felidae). *Mol. Ecol.* 10:65-79.

Natural History, Behavior, and Social Organization

William K. Baker Jr., Little Rock Zoo

INTRODUCTION

The jaguar is the mightiest carnivore in its range and has long inspired the awe and fear of the people who have shared the land with it. To pre-Columbian people the jaguar was a deity. Approximately twenty-five hundred years ago the Olmecs, first carved likenesses of the jaguar into statues of jade and stone and even carved human figures with jaguar heads. Reaching its prominence in Mesoamerica around 1200 B.C., the Olmec culture and its art were suffused with human-jaguar figures. It is believed that the Olmecs were ruled by the earliest of the jaguar cults. Later, Mayan high priests took to wearing jaguar robes in their society. The Mayans created a highly advanced civilization that was recognized for exceptional achievements in mathematics, astronomy, and medicine. Mayan culture considered the jaguar to be a personification of fear and death, and the dark images carved in stone have kept watch throughout time from Mayan temples, tombs, and thrones.

The neighboring Aztecs of Mexico were a warlike society that practiced ritual human sacrifices on jaguar-headed altars. Within the Aztec culture were the Jaguar Knights, considered to be elite warriors and revered in their society. The name jaguar is based in Amazonia and actually comes from the Guarani Indian word, *yaguara*, which translated means “a wild beast that kills its prey in a single bound”. The scientific name for the jaguar, *Panthera onca*, which translated means “hunter for all” in homage to the jaguar’s position as an apex predator and “hook-barb” in reference to the jaguar’s claws. Regardless of the name used, as the largest and most magnificent of the New World cats, the jaguar continues to remain shrouded in mystery and legend drifting through the jungles and collective consciousness of Latin American culture.

The jaguar has been under considerable pressure due to conflict with the livestock industry in Latin America for many years; yet it has long been considered one of the premier cats for zoological institutions to exhibit at their facilities. As the largest felid found in the Americas, the jaguar has the rare ability of providing a high-impact exhibit for the public when this species is on display and a venue for conservation and education. Utilizing an integrated approach to graphics and text, the public can easily be made aware of the jaguar’s plight of habitat loss, fragmentation, and human persecution throughout its range.

HISTORY

Few have studied the biology of the jaguar (*Panthera onca*) until recently. This fact is quite remarkable considering that the jaguar is the third largest living cat in the world and the largest cat in the Americas. Its geographic distribution covers a considerable part of Mexico, all of Central America, and South America as far as northern Argentina. The exception to this is Uruguay where it has been extinct since the early 1900s, and the southwestern United States where it is found only on the United States-Mexico border (Nowak 1994, Swank and Teer 1989, Brown and Gonzales 2001). Information preceding 1970 when available consists mainly of anecdotes and notes on the animal’s natural history [von Humbolt 1852-53; Rengger 1830; Azara 1838; Roosevelt 1914; Cherrie 1930; Miller 1930; Krieg

1948; Wavrin 1951; Kulhorn 1955; Leopold 1959; Sick 1960; Brock 1963; (Hoogesteijn and Mondolfi 1982)].

Since that time a number of papers have been published on the jaguar. A study of the adaptive differences in the body proportions of large felids was addressed by William J. Gonyea (1976) who compared body proportions in eight large felids, including the jaguar, to determine whether functional differences due to morphological variation could be correlated with different behavioral and ecological strategies. Later, Schaller and Crawshaw (1980) undertook what is considered by many to be the first serious distribution study using radio telemetry in April 1978 at the Acurizal Ranch in the Pantanal Region, State of Mato Grosso, Brazil.

The status of the jaguar in the southwestern United States was investigated and addressed by David E. Brown of the Arizona Game and Fish Department (1983). His paper dealt with a historical overview of jaguars that had been killed in Arizona and New Mexico and the resulting long-term population dynamics. During this same period *ex situ* research progressed as the use of drugs to control estrus in female *Panthera* species in captivity was tested (Gardner, Hueston, and Donavon 1985). Further study of the ecology and behavior of the jaguar was conducted in the Cockscomb Basin of Belize by Rabinowitz and Nottingham (1986). Still, the first comprehensive paper on the biology of the jaguar as a whole was presented by Mondolfi and Hoogesteijn (1982). Their study of the biology and status of the jaguar in Venezuela was the first to integrate all aspects of the jaguar's biology into a concise format. This is not to say Schaller's work (1978-1980) is not significant; his was the first in-depth field work of a scientific nature performed with the jaguar and still remains the standard by which all other research work is judged for this species. It should also be noted that the Wildlife Conservation Society (WCS) has historically underwritten several invaluable field expeditions devoted to the *in situ* study of the jaguar, [Schaller and Crawshaw (1980) and Rabinowitz and Nottingham (1986)].

HABITAT

In habitat selection, jaguars require a water supply, dense cover, and sufficient prey (Mondolfi and Hoogesteijn 1982). It would appear then that the jaguar resembles the tiger (*Panthera tigris*) in its habitat requirements and would reflect another correlation to a solitary cat. In the Southwest, the jaguar was typically found in the roughest and densest terrain available, specifically the following: a Madrean evergreen-woodland, shrub-invaded semi-arid grasslands, and river bottoms (Brown 1983). In Florida the favored habitat was typically dense swamp (Line and Ricciuti 1985). "In Venezuela the jaguar has been found in a variety of habitats. In the southern part of the western llanos (in the States of Apure, Barinas, and Portuguesa), the jaguar inhabits lowland tropical humid forest and lowland deciduous forest, showing a preference for riverine forest with adjoining grassy plains (flooded savanna, swampy savanna, and marsh land). It has a special liking for watercourses, lagoons, and swamps. In the forests bordering rivers and *canos* (slow-moving streams), some of which dry up during the dry season, the jaguar finds shelter in the very dense, almost impenetrable under story formed by tangled tree roots, low spiny palms and other plants. In the southern part of the eastern llanos on the coast of the Orinoco River, the jaguar is found in small riverine forest habitats. At El Socorro, near El Baul, in the southern part of the State of Cojedes, ...the habitat is swampy palm savanna with some densely forested islands, and rocky wooded hills with mountain creeks. Jaguars use

some of the caves on the rocky outcrops as dens”; (Mondolfi and Hoogesteijn. “Jaguar in Venezuela”, pp 91-92, *CATS OF THE WORLD*: 1986).

Conversely, the jaguar’s ability to adapt to a habitat is not limited by a shift in elevation. “In the northern part of the country, the jaguar inhabits premontane humid and semi-deciduous forest, preferring wooded country with adjoining pasturelands used for grazing cattle. In the *Cordillera de la Costa* (northern Coastal Mountain Chain), the jaguar may extend its distribution into the humid montane forest to an altitude of about 1000 meters, and occasionally it may enter the cloud forest at 1750-2000 meters above sea level. Humid lowland forest or semi-deciduous forest with neighboring pastureland is used by jaguar in the coastal fringe between the States of Carabobo and Yaracuy. Jaguars are also found in the rocky hilly country covered with seasonal deciduous forest and scrubby vegetation called *galeras* in the northern part of the State of Guarico. In the state of Zulia, jaguars are found in premontane humid forest at the Sierra Perija and in the humid forests and swampy land on the southwestern part of Lake Maracaibo, where several cattle farms are located. In the State of Bolivar the jaguar inhabits lowland riverine forests, swampy savannas with Maurita palm groves, densely forested hills and rain forests. At the Gulf of Paria (State of Sucre and Amacuro) and in the Orinoco Delta, Territorio Delta, the jaguar inhabits flooded riverine forest, swampy lands and mangrove. In the Amazon Territory the jaguars habitat is the rain forest and particularly riverine forest” (Mondolfi and Hoogesteijn, “Jaguar in Venezuela”, pp 92-93, *CATS OF THE WORLD*: 1986).

Schaller and Crawshaw conducted both of their studies (1978-1980) on the Acurizal Ranch in the Mato Grosso State of Brazil. It is located along the western edge of the Patanal, a vast plain that is flooded partially on a seasonal basis by the Paraguai River and its tributaries, is 136 square kilometers in size. Overlooking the ranch is a high ridge covered on its upper slopes by an open type of woodland that continues to the lower slopes and a base that is covered by a mosaic of cattle pastures, thickets, and stands of semi-deciduous forest, with trees that range up to 20 meters in height.

Interspaced between the Rio Paraguai and its tributaries is an extensive flood plain whose margins form meadows and gallery forests. This area has been mostly inundated since a flood occurred in this region in 1974. This produced a narrow grassy beach that separates the waterline from the forest edge on the high ground, which provides an ideal hunting area for the resident jaguars. The leguminous trees in the area tend to shed their leaves so that by August they are bare, leaving grass as the main cover with occasional bamboo thickets. However, in each valley, a perennial stream facilitates drainage. These streams are bordered by evergreen forest with trees of up to 25 meters providing a cool moist gallery forest. The forest provides cover for wildlife when the surrounding cerrado becomes hot and dry.

HOME RANGE

The home range of the jaguar has been established to be 25 to 38 kilometers for females and at least double that for males (Schaller and Crawshaw 1980). However, jaguars in the Pantanal Region of Brazil were reported to have home ranges of twice that figure. Adult males had a home range of 28 to 40 kilometers, conversely the females moved over a minimum area of 10 kilometers. Adult males typically had a home range that encompassed several females (two to three) territory and would defend it against all jaguars except sub-adults and females (Schaller and Crawshaw 1980). In the event of a

jaguar's death, a jaguar that had a contiguous home range filled that vacant home range, and that range was then filled in turn by a jaguar from an outside territory (Rabinowitz 1986).

TERRITORIALITY

Larger felids may exhibit behavioral similarities at times, still it should be understood that there may be discrete differences between them. "*Panthera* cats such as the lion (*Panthera leo*), tiger (*Panthera tigris*), and leopard (*Panthera pardus*) may delineate their ranges both directly by roaring and indirectly by scraping the ground with their hind paws...defecating or urinating on scrapes or at prominent locations, clawing trees, and spraying urine (Schaller 1978). The jaguar at Acurizal and Bela Vista seem remarkably restrained about advertising their presence by such methods. We spent many nights in the forest but never heard the characteristic jaguar roar, a sequence of loud, hoarse grunts. We followed fresh jaguar tracks for a total of 39 kilometers without noting a scrape, except once when a female had been chased by dogs. By contrast, puma (*Puma concolor*) at Acurizal left 10 scrapes in 16 kilometers; two scrapes had been marked with urine and one with feces. The route of tiger can often be detected from pungent urine marks left on bushes and trees (Schaller 1967), but that of jaguar could not. Feces were seldom discovered, possibly because jaguar made little or no effort to display them. Jaguar occasionally raked their claws down tree trunks, some trees being used repeatedly, but since puma showed similar behavior it was often impossible to ascertain which of the two cats had made the marks" (Schaller and Crawshaw, "Movement Patterns of Jaguar", *Biotropica* 12(3), P. 164, 1980).

However, Rabinowitz and Nottingham (1986) in their study performed in Cockscomb Basin, Belize, had no difficulty finding feces openly on cattle trails that were also used by the jaguar in the area. Their success was so significant that they were able to determine dietary habits of the regions' jaguar by physical examination. This may have been due to the overlapping home range of jaguars in the area. Mondolfi and Hoogesteijn (1982) noted that jaguars would leave claw marks on tree trunks, and it was believed that this was more to sharpen claws than to serve as any form of communication. They also made mention of a statement made by Darwin while he was hunting on the banks of the Uruguay River. He had noted that certain trees were marked at different ages by scratches. In a reference to Almeida it was noted that jaguars have favorite trees on which they will sharpen their claws. He specifically mentioned the *morcegueira* tree (*Andira inermia*) and the *sandregrago* tree (*Pterocarpus officinalis*). The *morcegueira* tree has a thick hardwood trunk and rough bark, and is found specifically in the northern swamps of the Pantanal of the Mato Grosso. It was reported that finding claw marks on one was a sure sign that a jaguar was in the area. At the El Socorro Ranch, near El Baul, Cojedes State, a *sandregrago* tree with a sloping trunk indicated scratches made by a jaguar. As the claw marks were at different heights, it was presumed that the tree was being used regularly for climbing.

VOCALIZATION

The key to maintaining a jaguar's territory would appear to be communication by vocalizations. It was reported that in some parts of the Mato Grosso Region (Capstick 1981), jaguars are often vocal. In Venezuela it was reported that they called often in some areas (Mondolfi and Hoogesteijn 1982). The vocalizations were described not as the true roar of a lion, but rather as being composed of a series of

five to a dozen repetitions of a short, hoarse coughing. This usually starts with short guttural “uhs” that increase in volume until after several repetitions the final “uhs” have appalling power and effect. Hunters in Venezuela often refer to this as “snoring”. By listening to tapes of a three-year old male jaguar in captivity, Mondolfi and Hoogesteijn (1982) were able to ascertain that males grunt in a sequence ranging from 17 to 22 vocalizations, with a longer time lapse between the last four to seven notes of each sequence.

The male has a stronger and more resounding call when compared to the softer call of the female, although the intensity of the female call will increase when entering estrus. It was also reported that males would call more frequently at the beginning of the rainy season. A female jaguar in heat will travel at night advertising her presence for a mate with a series of five to seven grunts that can be heard late into the night or until sunrise. When answering a female, the male’s call will be far more hoarse and guttural. The jaguar’s habit of answering a call of another individual is often taken advantage of by hunters who lure a cat by the use of a *corotear*, a call constructed out of a hollow gourd that is operated by either grunting into it or by pulling a piece of rawhide through it to simulate the characteristic jaguar grunt. As Capstick (1981) tells it, a device that is so effective, it once called a jaguar out of the water and into a canoe, requiring the hunters to beat it out of the boat with their paddles.

SOCIALIZATION

Until recently, very little was known about the behavior of the jaguar. Almeida was the first to provide any tangible observations of the jaguar in the wild in his book *Jaguar Hunting in the Mato Grosso* (1974). He notes that females had no set breeding season in the Pantanal area of the Mato Grosso. He reports hearing jaguars mating on numerous occasions and observed the tracks of pairs at varying times during different months. He also observes that females, upon coming into heat, moved about searching and calling for a mate far outside their normal territory. At other times he notes that the jaguar tended to be solitary and that it has a designated hunting territory that it will defend against intrusion from others of the same species and sex. Almeida mentions observing up to four males trailing a female in estrus and that males, killed during mating or shortly thereafter, were thin and out of condition. This could indicate that males forego hunting to a great extent during breeding.

Fighting over females is not common, but does occur among adult males. When male jaguars fight, it is normally over territory (Mondolfi and Hoogesteijn 1982). The female will not tolerate the presence of the mated male after the cubs are born as the male may kill and eat them. Similar behavior has been observed in tigers, as females with small cubs usually will not tolerate the presence of adult males in response to possible cannibalism (Mondolfi and Hoogesteijn 1982). This would also tend to support the theory that solitary cats exhibit similar behavior patterns based on territoriality.

Numerous accounts of male and female jaguars traveling together have been reported by eyewitnesses. At the La Vergarena Ranch, between the Aro and Paragua Rivers, State of Bolivar, a female believed to be in estrus was sighted with three males, one of which had a twisted leg and another that was melanistic. At the Matalopos Ranch, State of Apure, two ranch hands observed a female in estrus that was followed by two males. One of the males walked directly behind the female while trying to drive away the smaller male by means of roars, meows, and strikes at it (Mondolfi and Hoogesteijn 1982).

In the Pantanal region of Mato Grosso, Schaller and Crawshaw (1980) reported a male and an adult female together at the Acurizal Ranch killing, but not actually eating a lesser anteater (*Tamandua tetradactyla*). Capstick reported that “As a man-killer, opposed to a true, unprovoked man-eater, the tigre (jaguar) has impressive credentials... The jaguar very rarely turns to man-eating on a casual basis (compared to lion, tiger and leopard) but never unless in the case of still unrecorded insanity as a steady diet (Capstick, 1981). It was reported that a particular jaguar in the Xarayes Marshes Region was a man-killer named “Assasino” by the natives of the area for his particular habit of killing but not feeding. This was the case even with many prey species present (cattle, marsh deer, and dogs).

A witness according to Schaller and Crawshaw (1980) once encountered a group consisting of a male, a female, and two large cubs, as well as paired females and paired males on other occasions, which could indicate the possibility of a limited social life beyond that of the courting pair. Almeida (1974) states that when offspring are about one and a half years old, they leave their mother. Two siblings may live and hunt together for a few months while searching for their own territory, and upon finding an appropriate area, they may establish themselves contiguously.

In areas of heavy jaguar population, young males are forced to lead nomadic lives, moving into the home range of older males and being chased out until they become established in their own home range. Schaller and Crawshaw (1980) report that at the Acurizal Ranch, a female jaguar that was independent and at least two years old continued to share her mother’s range. Each traveled alone, except on one occasion when they shared a kill, yet their tracks tended to be in the same area at the same time. This association continued until they both were killed at the same time. The young female was believed to be approximately two and a quarter years of age at time of death.

ACTIVITY

Jaguars are primarily a nocturnal felid in their feeding and movement (Schaller and Vasconcelos 1978; Mondolfi and Hoogesteijn 1982). They usually tend to rest between mid-morning and afternoon, but some daytime activity and movement is fairly common and they will even hunt during the day when compelled. Schaller and Crawshaw (1980) established, by means of radio telemetry, that the supposedly nocturnal jaguar often wanders during the daylight hours. In studying the habits of a collared female, they determined that the jaguar often wandered about at mid-day, although she was most active the hours after dusk until dawn. During the day, jaguars lie down and rest, always in deep shade and usually in thick cover, sometimes in caves under boulders or in large holes in riverbanks called *solapas*. They have been known to rest outstretched on thick horizontal tree limbs. In certain regions, during the flood season, jaguars are forced to climb trees in order to find a dry resting place (1974). The peak activity hours noted were:

Predawn:	0330-0600 hours	(active)
Late morning:	0930-1200 hours	(rest)
After dusk:	1830-2100 hours	(active)
Midnight hours:	0030-0300 hours	(rest)

The jaguar is very dependent on water and consequently has a marked preference for the immediate vicinity of watercourses and lagoons (Mondolfi and Hoogesteijn 1982). Being near water becomes

imperative during the dry season when water becomes scarce and the jaguar must drink more frequently. As a consequence, the jaguar must seek cover near isolated pockets of water. It has been observed on numerous occasions that jaguars are water-loving cats, probably the most water-loving felids in the world, notes Almeida (1974). He reports that jaguars often seek relief from the heat in rivers. In fact, he sighted a jaguar swimming across the Orinoco River during the rainy season when the river was 8 to 10 kilometers wide. It is a very able swimmer capable of even carrying a kill in the process. A jaguar was sighted in the Cano Ave Maria carrying a heifer kill, which it then hauled on top of a tree that was above the flood level (Almeida 1974).

PREDATION

The jaguar utilizes a characteristic *Panthera* killing technique, typified by attacking with a deep bite to the throat that suffocates the prey. However more often than not, an attack where a bite pierces the back of the skull at its weakest point is used, frequently crushing the zygomatic arch. The bite has such precision as to place the canines precisely in a 3 by 3 inch area, which at times correlates with canine placement into the ear and cranium of its prey. Afterward the jaguar drags the prey to a thicket or secluded spot. The digestive tract is usually removed two to three meters away. The ventral surface of the prey is eaten first: neck, chest, heart and lungs, and then the shoulders (Schaller and Vasconcelos 1978).

The jaguar uses a slightly different technique for reptiles. The jaguar pounces on crocodilians from behind immediately biting through the neck and thereby severing the cervical vertebrae. This renders the reptile unable to escape into the water. When eating a turtle, the jaguar introduces its paw into the shell through the opening between the carapace and plastron and scoops out the flesh without breaking the shell. Porcupines are simply flipped onto their dorsal side, and the exposed flesh is scooped out with the paw (Mondolfi and Hoogesteijn 1982). Even though the jaguar's diet is diverse and dependent on geographic location, prey species commonly include: capybara (*Hydrochaerus hydrochaeris*), spectacled caiman (*Caiman crocodilus*), side-necked turtles (*Podocnemis vogli*) and (*Podocnemis unifilis*), and the collared peccary (*Tayassu tajacu*), (Mondolfi and Hoogesteijn 1982; Schaller and Vasconcelos 1978; Guggisberg 1975)

In all cases the jaguar attacks from cover, and usually from a blind side with a characteristic pounce. As an ambush predator, the jaguar has few peers in the animal kingdom and is accorded a high degree of respect by not only field researchers, but also by indigenous people as well. In retrospect, this comes as no surprise when considering that the jaguar as a species has effectively adapted to a multitude of ecosystems and has the ability to function as an apex predator in its established range.

REFERENCES

- Almeida, A. de. 1974. *Jaguar Hunting in the Mato Grosso and Bolivia*. Long Beach: Woodbine-Safari Press. 1990.
- Brock, S.E. 1963. The Jaguar (*Panthera onca*). *J. Br. Guiana Mus. Zoo* 37:46-48.
- Brown, D.E. 1983. On the Status of the Jaguar in the Southwest. *Southwestern Nat.* 28:459-460.

- Brown, D.E., and C.A. Lopez Gonzales. 2001. *Borderland Jaguars*. Salt Lake City: University of Utah Press.
- Capstick, P.H. 1981. *Maneaters*. Long Beach: Safari Press.
- Crawshaw, P.G. Jr. 1987. Top Cat in a Vast Brazilian Marsh. *Anim. King.* 90(5):12-19.
- Crawshaw, P.G. Jr., and H.B. Quigley. 1991. Jaguar Spacing, Activity and Habitat Use in a Seasonally Flooded Environment in Brazil. *J. Zool. Lond.* 223:357-370.
- Ewer, R.F. 1973. *The Carnivores*. Ithaca: Comstock-Cornell University Press.
- Goldman, E.A. 1932. The Jaguars of North America. In: *Proc. Biol. Soc. Wash.* 45:143-146.
- Gonyea, W.J. 1976. Adaptive Differences in the Body Proportions of Large Felids. *Acta. Anat.* 96:81-96.
- Gonyea, W.J., and R. Ashworth. 1975. The Form and Function of Retractable Claws in the Felidae and Other Representative Carnivorans. *J. Morphol.* 145:229-238.
- Guggisberg, C. 1975. *Wild Cats of the World*. New York: Taplinger Press.
- Humbolt, B.A. von. 1852. *Travels to the Equinoctial Regions of the New Continent*. T. Ross, ed. London: Bohn.
- Humbolt, B.A. von. 1853. *A Personal Narrative of Travels to the Equinoctial Regions of America During 1799-1804*. London: Bohn.
- Line, L. and E.R. Ricciuti. 1985. *The Audubon Society Book of Wild Cats*. New York: Chanticleer Press. p 168-183.
- Leopold, A.S. 1959. *Wildlife of Mexico*. Berkeley: University of California Press.
- Mearns, E.A. 1901. The American Jaguars. In: *Proc. Biol. Soc. Wash.* 14:137-143.
- Miller, F.W. 1930. Notes on Some Mammals from Southern Mato Grosso. *J. Mammal.* 11:10-22
- Mondolfi, E., and R. Hoogesteijn. 1986. Notes on the Biology and Status of the Jaguar in Venezuela. In: *Cats of the World: Biology, Conservation, and Management*. S. D. Miller and D. D. Everett, eds. Washington, DC: Nat. Wildl. Fed. p 85-123.
- Nowak, R. 1975. Retreat of the Jaguar. *Natl. Parks Conserv. Mag.* 49(12):10-13.
- Nowak, R. 1991. *Walker's Mammals of the World*. 5th Edition. 2nd Volume. Baltimore: Johns Hopkins Univ. Press.

- Nowak, R. 1994. Jaguars in the United States. *Endangered Species Technical Bulletin*. 19(5):6.
- Quigley, H.B. 1987. *Ecology and Conservation of the Jaguar in the Pantanal Region, Mato Grosso do Sul, Brazil*. Ph.D. dissertation. Univ. of Idaho, Moscow.
- Rabinowitz, A.R. 1986. *Jaguar*. New York: Arbor House.
- Rabinowitz, A.R. 1986. Jaguar Predation on Domestic Livestock in Belize. *Wildl. Soc. Bull.* 14:170-174.
- Rabinowitz, A.R. and B.G. Nottingham. 1986. Ecology and Behavior of the Jaguar (*Panthera onca*) in Belize, Central America. *J. Zool. Lond.* 210:149-159.
- Rengger, J.R. 1830. *Naturgeschichte der Saeugethiere von Paraguay*. Basel: Schweizerischen, Buchhandlung.
- Rich, M.S. 1976. The Jaguar. *Zoonooz*. 49(9):14-17,
- Roosevelt, T. 1914. *Through the Brazilian Wilderness*. New York: Scribners. Schaller, G.B., and J.M.C. Vasconcelos. 1978. Jaguar Predation on Capybara. *Z. Saugetierkunde*. 43:296-301.
- Schaller, G.B., and P.G. Crawshaw. 1980. Movement Patterns of Jaguar. *Biotropica* 12(3):161-168.
- Schaller, G.B., H.B. Quigley, and P.G. Crawshaw. 1984. Biological Investigations in the Pantanal, Mato Grosso, Brazil. *Nat. Geogr. Res. Rep.* 17:777-792.
- Stehlik, J. 1971. Breeding Jaguars (*Panthera onca*) at Ostrava Zoo. *International Zoo Yearbook*. 11:116-118.
- Swank, W.G., and J.G. Teer. 1989. Status of the Jaguar-1987. *Oryx*. 23:14-21.
- Swank, W.G., and J.G. Teer. 1990. The Jaguar-A Symbol of Conservation Efforts in Latin America. Denver, CO. International Conservation In: *Wildlife Management Inst. North American Wildlife & Natural Resources 55th Conf.*
- Wallace, A.R. 1853. *A Narrative of Travels on the Amazon and Rio Negro*. London: Reeve and Co.

Captive Management

William K. Baker Jr., Little Rock Zoo

INTRODUCTION

The jaguar (*Panthera onca*) has long been considered one of the premier cats for zoological institutions to exhibit at their facilities. As the largest felid found in the Americas, the jaguar has the rare ability of providing a high-impact exhibit for the public when this species is on display and a venue for conservation and education. Utilizing an integrated approach to graphics and text, the public can easily be made aware of the jaguar's plight of habitat loss, fragmentation, and human persecution throughout its range. The jaguar has been under considerable pressure due to conflict with the livestock industry in Latin America for many years. This conflict raises the issue of mutual coexistence (Rabinowitz 1986). As a result, the jaguar is listed as endangered by the USFWS, Appendix I by CITES, near threatened by the IUCN. The AZA Jaguar Species Survival Program (SSP) currently oversees the captive North American population.

As an apex predator, the jaguar has no peer within its terrestrial range. As such, it is understood that the jaguar can be a challenge to effectively manage in captivity. However, by developing an interdisciplinary approach to the daily husbandry for this species that utilizes communication, planning, evaluation, and revision as needed, it is possible to manage jaguars effectively in a modern zoological institution. Still, this requires that front-line animal managers utilize effective communication and detailed record keeping to enable the senior staff of an institution to make informed decisions based on not only on specific animal personalities but also on the species. This section provides the zoological professional with a ready reference, organized into an outline format for ease of use.

HUSBANDRY REQUIREMENTS

Demographic Data

The jaguar has a long history of successful breeding in North America and in AZA institutions. Many of the unmanaged animals are in the fourth to fifth captive generation. Over the period 01 January 1970 – 01 March 2003 a life table analysis depicts a population capable of growing at 5% annually (Table 1). A much greater population growth rate is likely possible if more pairings were attempted. Jaguars can live until their mid-20s and can reproduce through age 20 with a few recorded births in the mid-20s. Therefore, the prospect of growth in the jaguar population is good, if sufficient known-pedigree jaguars can be obtained and put in breeding situations. The SSP managed population in April 2003 consists of 22 (11.11) jaguars most of which are of breeding age. This is an increase from 16 (9.7) traceable jaguars in 2001.

Sanitation

Cleaning protocols vary among zoological institutions. Accepted procedures traditionally include inspecting a naturalistic exhibit to remove fecal material, waste products, and enrichment items. Water features that do not incorporate filtration systems should be drained and sanitized on a schedule or as needed. Night house operations and exhibits that utilize hard surface floors in the keeper work areas, shift corridors, individual holding units, and enrichment items should include daily removal of fecal material. It is good practice to implement a regular cleaning and sanitizing schedule incorporating detergents (examples include lotionized soap and degreasing dish detergents) and disinfecting agents (examples include quaternary ammonium disinfectants, phenols, chlorhexidine and diluted bleach). After any chemical application, surfaces should be rinsed with a high-pressure water stream. Access should not be provided until wet areas have dried to prevent injury. Many institutions place disinfecting footbaths at exhibit and night house entry points, especially in areas in which keeper service a number of exhibits containing diverse species. Steam cleaning of hard surface areas is recommended annually, where practical.

Pest Control

An effective and safe method of controlling insects and rodents is mandated, and accurate records should be kept to reflect supervised monthly licensed pest control inspections and service. Rodent control can be achieved using snap traps, glue boards, and other non-chemical systems. Poison baits should be used only when there is no possibility of felid access to the bait or to treated rodents resulting in secondary poisoning. Bait traps are highly effective, but must be kept dry and should be refilled at regular intervals. Insect control may include electronic insect killers, growth inhibitors, pest strips, and natural or synthetic pyrethrins. All chemicals should be veterinarian approved prior to use.

Veterinary Care

This paragraph should also make reference to the complete veterinary chapter later in the guidelines.) A licensed veterinarian should be available at all times. Quarterly fecal examinations are recommended to check for parasites. Annual physical exams under anesthesia should be performed on a yearly basis; these exams should include a complete physical inspection, and measurements of an accurate weight and body temperature. Dental scaling and polishing should be performed during the examination. Blood samples should be drawn for CBC, chemical panel, heartworm antigen testing, thyroid screen, and serology tests for FIP, FIV, FeLV and toxoplasmosis. A rectal culture for salmonella and urinalysis is recommended. Vaccinations should be given for feline calicivirus, rhinotracheitis, panleukopenia (FVRCP), feline leukemia (FeLV), and rabies (Canary-Pox). Implanted microchips should be verified for accuracy against veterinary records.

For detailed animal health information and recommendation, please refer directly the Health Care chapter of this volume.

Daily Management

Animal managers should establish safe access to the night house prior to entry. Lights should be activated before leaving the double containment door system and entering the keeper work area. An accurate animal count should be performed before proceeding with daily husbandry procedures. Exhibits are normally serviced first for sanitation, followed by primary containment and hot-wires inspection. Afterwards specimens are shifted onto display. Animal transfers may utilize shift corridors that incorporate restraint devices, scales and holding units for daily procedures. Cleaning and

sanitation procedures are then performed on the holding areas. Maintenance repairs to the holding areas should be performed while specimens are on display. Staff members should be aware of animal locations and the status of locks at all times during animal husbandry procedures.

Most large felids are solitary in nature except during periods of breeding activity. As a result, extreme caution and patience is recommended during introductions to facilitate pairings. Females in estrus can exhibit behaviors including restlessness, pacing, rolling, and prolonged vocalizations (Stehlik, 1971). Compatibility between animals can be achieved through extended controlled introductions in a night house shift area or adjacent enclosure that allows auditory, olfactory, and visual contact, but prevents actual physical contact. Utilizing such “howdy” barriers, an introduction schedule can be set up over a period of days or weeks to gradually reduce them until the animals are introduced into the same space. Safe measures to separate the cats, such as water hoses or CO₂ fire extinguishers, are recommended to be available in case of aggression.

The species may exhibit a variety of reactions to changes in daily routine, weather, animal care staff or physical changes in the building or exhibit. Care should be taken to note behavioral changes and minimize conditions causing the animals to display signs of stress. Loud or repetitive noises, unusual activity, and unknown personnel in off-exhibit or night house areas may act as potential triggers for aggression, while on-exhibit public distractions are often totally ignored. Stability and routine should be considered positive environmental modifiers. Relevant to successful husbandry and reproduction are stable behavior patterns established between animal keepers and exotic felids. Keeper interaction through feeding, vocalization, tactile behavior, and operant conditioning develops a positive exchange with a cat and should be considered an integral part of this relationship.

ENVIRONMENTAL REQUIREMENTS

Temperature

Animals kept outside should always have access to shade, and/or water features during the warmer months of the year, especially when temperatures exceed 90° Fahrenheit. Zoological institutions located in northern climates are urged to consider developing indoor exhibits or provide supplemental heat for specimens when the temperature drops below 50° Fahrenheit. However, provided adequate shelter from wind and acclimated to conditions, jaguars can tolerate conditions down to 30°. Individual animals’ acclimation, heat index, humidity and wind chill affect tolerance of temperature variations; so animal managers can use judgment in deciding to place jaguars outdoors in cool climates. Providing sections of varying shelter and sunlight exposure in an exhibit can create temperature zones that permit the animals to select the most comfortable location. When kept indoors, specimens should be protected from temperatures exceeding 85° Fahrenheit through the use of circulating fans or air conditioning.

Humidity and Ventilation

Animals may be housed outside during warmer weather with adequate ventilation and with the opportunity to adapt to increasing humidity levels over time. However, indoor exhibits should

maintain a relative humidity of 30 to 50%. This will prevent excessive condensation on glass surfaces, which interferes with effective viewing of specimens on display.

While the number of air changes per hour of non-recirculated air will be dependent on the number of animals in an enclosure and the size and volume of an enclosure, the standard rate of air exchange is 1.0 cubic feet for non-recirculated air/minute/square feet of floor space. Indoor exhibits should have a negative air pressure of 10 to 15 air changes per hour. Proper ventilation should be considered an integral facet of exhibit design to promote cooling, control odors, and reduce the risk of disease transmission among specimens. Glass barriers and separate ventilation systems between exhibit and public areas should be effective in controlling potential disease transmission and problematic odors.

Lighting

Due to their size, most large felids are housed in outdoor exhibits that utilize ambient lighting. However, some institutions have developed indoor exhibits that require the use of skylights or artificial lighting. Because jaguars jump and climb well, it is recommended to install cage-strength mesh barriers to prevent skylights functioning as primary containment. Light levels should be appropriate to provide unrestricted viewing by the staff at all times due to safety considerations, especially during night house operations. Most large felids adapt well to normal light cycles and usually do not present negative behaviors. Fluorescent lighting is acceptable and is commonly used as an artificial light source indoors, but full spectrum UV bulbs are recommended to diminish aggression in certain large felids held in indoor enclosures, (Baker and Hainley, in press).

Water

Clean potable drinking-quality water should be available at all times; this includes availability of water on and off-exhibit. Watering devices take many forms dependent on budget and design, and include but are not limited to built-in containers, concrete basins, stainless steel bowls and pans, and automatic waterers. In cold climates, installation of means to prevent pipes freezing may be an important consideration. A drawback to using lick valve automatic waterers is the potential of a specimen damaging its teeth and/or damaging plumbing through biting the waterer. Water supplies should be easy to clean and disinfect and sanitation should be managed on a daily basis.

Substrate

Natural substrates associated with outdoor exhibits such as grass and dirt are preferred, but many facilities do maintain specimens on hard surface enclosures. It should be noted that one specimen kept in a concrete enclosure exhibited cracked pads and early symptoms of arthritis in its foreleg.

EXHIBIT REQUIREMENTS

Design Parameters

While standard cage configurations can be used, naturalistic exhibits that utilize complex artificial or natural features, which enter the vertical plane, should be considered the optimal design to maximize available square footage and decrease animal loading in the enclosure. Exhibits should be designed to reflect the naturally occurring felid behaviors of territoriality, scent marking, and the defense of home range against conspecifics. Exhibits should be designed to minimize psychological pressure from

viewers. Vegetation, rockwork and climbing structures may help reduce stress. Water features are highly recommended and should contain deep (>1meter) and shallow areas to stimulate play activity.

Primary Containment

Exhibits and off-exhibit holding areas should be designed to provide the highest level of security for this species. If possible, institutions should consider completely enclosing the top of any jaguar containment. Dry moats should have a width of no less than 25 feet and vertical jump walls at least 15 feet high are recommended. Cantilevered supports with mesh or fencing material with an attached hot-wire is recommended for open-top fenced exhibits. As this species is a strong jumper and climber, an impenetrable roof at the 12-foot mark should be considered, in order to defeat climb-outs or a leaping ricochet off an adjacent structure or prop. In any event, great care should be taken in placement of landscaping and exhibit furniture to avoid the possibility of their use by cats to reach areas in which public, animals or staff may be injured. Consideration should include prevention of a stepping stone effect by animals jumping from one landscaping element to another in order to reach a location otherwise out of reach. Fence or mesh material should be no less than 6-gauge composition with good results achieved with 2x4-inch mesh and custom woven meshes. However, a mesh measuring no more than 2x2 is recommended in keeper work areas. Lightweight mesh is not appropriate for this species. Also, when using a flexible mesh the potential increases for damage to teeth or the mesh itself because jaguars often bite or pull it.

Enclosure Size

Outdoor enclosure size should be no less than 300 square feet with 50% additional square footage per each specimen. Indoor enclosures should be no less than 20x15 feet and 50% additional square footage per specimen, with a minimum exhibit height of 8 feet and a recommended height of 10 to 12 feet, with 12 feet considered the better choice. Additional square footage beyond the base recommendation would be considered optimal to facilitate introductions and breeding pairs while reducing potential aggression.

Enclosure Components

Like many felids, this species is comfortable on the ground as well as in trees. As a result, enclosure designs should incorporate climbing structures of live, dead, or artificial tress. Artificial snags or ledges should be incorporated into the exhibit design that produce elevated resting sites and long distance viewing that promotes security. At least one resting site per animal should be provided. Artificial and natural rocks can be utilized to provide visual and auditory barriers, which when used in conjunction with other features should produce multi-level complex pathways reducing stereotypic behaviors. Landscaping should be maximized to simulate natural cover and promote walkways, thereby reducing stress by providing environmental enrichment, escape routes, and shade – natural trees probably being the most beneficial. Plant toxicity should be ascertained prior to planting an enclosure with landscaping materials.

Night Holding

Every specimen should have its own individual shelf or nest box in a shift cage which is utilized while the animals are off-exhibit during enclosure maintenance and servicing. The minimum recommended size for shift cages used in daily operations should measure no less than 8x8x8 feet. Shift cages should be designed to prevent accidental contact that would allow an appendage to enter the cage of an adjacent, incompatible cat, resulting in injury. Shift doors should be designed to prevent tail injury

during transfer procedures. Optional “howdy” doors should be considered between individual holding units to facilitate introductions. Isolated birthing dens that have low-light capabilities and reduced human foot-traffic activity should be available for institutional breeding programs. Provision for a closed-circuit television monitor is suggested as well.

SPECIAL REQUIREMENTS - SAFETY

Public Barriers

Secondary guardrails should be utilized wherever the potential exists for public contact with primary containment fencing or mesh materials. Designers should consult state or local regulations and guidelines for public barriers to exhibit contact. The public should be protected from unauthorized contact with zoo animals. Public viewing points composed of tempered glass are commonly used in conjunction with interpretive graphics and do not require the use of secondary guardrails. Moated exhibits do not necessarily require guardrails, but they do tend to discourage the public from climbing onto or placing children on the gunite containment wall. As moat walls act as a form of primary containment, a height of no less than four feet is recommended and the vertical surface should lack footholds.

Escape

This species is normally classified as a dangerous animal by most zoological facilities and extreme caution should be exercised in the event of an escape situation. It is understood that every zoological institution and its animal collection will differ. As a result, it is strongly recommended that each facility and its animal managers develop escape procedures specific to their needs. One of the best information sources currently available to assist in animal escape procedures is the AZA Resource Center which can be referenced online at www.aza.org > Resource Center > Safety and Risk Management > Sample Documents > Animal Escape Procedures.

Note: In addition to this document, it may be helpful to read the AZA Husbandry Standards. Updated from time to time, they are available on-line at www.aza.org > Members Only > Resource Center > Husbandry > Minimum Husbandry Guidelines for Mammals > Felids, Large.

REFERENCES

- Baker, William K. Jr. 1996. Biology of the Jaguar. *Animal Keepers' Forum*. 23:542-546, 587-594.
- Baker, William K. Jr., and Patricia M. Hainley. 2003. “The Ethological Response of a Captive Cougar (*Felis concolor*) to Variances in Illumination of an Indoor Exhibit”. Unpublished Research, 2002.
- Barbiers, Robyn. DVM, and William K. Baker Jr. 1999. Emergency Preparedness for Large Carnivores: Bears and Cats. In: *AVMA Disaster Preparedness and Response*. Schaumburg: AVMA. F-13:344-345.
- Ewer, R.F. 1973. *The Carnivores*. Ithaca: Comstock-Cornell University Press.

Line, L., and E.R. Ricciuti. 1985 *The Audubon Society Book of Wild Cats*. New York: Chanticleer Press. pp. 168-183.

Macdonald, David, PhD. 1987. *The Encyclopedia of Mammals*. New York: Facts on File Publications.

McMillan, Greta. 1996. *Regional Studbook for the Jaguar (Panthera onca)*. 1st Edition. Kim Widner ed. Knoxville: Knoxville Zoo Press.

Mellen, Jill D. 1997. Optimal Environment for Captive Felids. In: *Plan Regional Para El Manejo La Conservacion De Los Felinos Mesoamericanos*. San Jose: Fundacion Pro Zoologicos, Universidad Nacional, and NOAHS Center.

Nowak, R. 1991. *Walker's Mammals of the World*. 5th Edition, 2nd Volume. Baltimore: Johns Hopkins Univ. Press.

Rabinowitz, A.R. 1986. *Jaguar*. New York: Arbor House.

Shoemaker, Alan H. 2003. Zoo Standards for Keeping Large Felids in Captivity. *AZA Minimum Husbandry Standards for Mammals*. Silver Spring, MD: AZA Publishing. In Press, 2002.

Stehlik, J. 1971. Breeding Jaguars (*Panthera onca*) at Ostrava Zoo. *International Zoo Yearbook*. 11:116-118.

Transport

Stacey Johnson, Fort Worth Zoo

Successful transportation of jaguars requires thorough and careful preparation and planning. The health and safety of both cats and humans must be considered at every step.

The AZA's *Zoo Standards for Keeping Large Felids in Captivity* provides excellent suggestions for transporting big cats. They can be found on the web at www.felidtag.org. Look for the title under New Information in the table of contents. Section 1.4 entitled "Space" includes crate design and factors affecting safe transport.

Health certificates, transaction paperwork, air-bills and other documents are frequently shipped along with animals. Attaching a clearly marked envelope to the crate with clear packing tape is a convenient method. A document outlining details of the sending institution's husbandry procedures, diet, and behavior notes is an important component of this paperwork. The Animal Data Transfer Sheet, a form printed by the American Association of Zoo Keepers, is a convenient method.

ADT forms are available from Barbara Manspeaker, AAZK, 3601 SW 29th Street, Suite 133, Topeka, KS 66614. Telephone 785 273-9149; email: aazkoffice@zk.kscoxmail.com

Training jaguars to enter a shipment crate in advance of actual transport is highly recommended and can be accomplished using standard positive reinforcement techniques. This eliminates the need for general anesthesia and its accompanying psychological and physiological stress.

Environmental temperature is an important consideration in the loading process as well as during actual transport. Especially if anesthesia or sedation is utilized, animals may experience sudden dangerous increases in body temperature. Precautions to avoid over-heating, such as time of year and loading in early morning, should be considered.

The quickest method, with the fewest stops and transfers, is usually the best way to transport jaguars. It can be helpful to contact zoos along the route, prior to transport, in case assistance is needed along the way. A number of professional animal transporters are listed in the AZA Directory as Commercial Members.

Several major airlines continue to provide animal-shipping services, as well. Increased security restrictions on air travel in general, and changes in policy by individual airlines make it vital to build relationships with local air carriers. Successful air transport of jaguars depends on the zoo shipper's understanding of regulations, policies and logistics. Likewise, maintaining open dialogue with local airline cargo agents creates an opportunity for them to provide helpful advice and improved service.

Many aircraft cargo bays provide ample space for animal crates. However, it is extremely important to note that the size of the cargo hatch will limit the size of the crate. Consult with the airline, or find aircraft specifications on the airline's website, for exact measurements.

Annually, the International Air Transport Association (IATA) publishes animal transportation guidelines, which are available for a fee. Airlines in the United States utilize these guidelines to determine the suitability of any animal crate for use in transport. Constructed to IATA guidelines, crates provide adequate space. However, it is important not to make them too large. Injuries may occur if vents are large enough to encourage animals to attempt escape, or if space permits animals to leap or be thrown about within the crate.

Given zoological institutions' frequent use of commercial transport companies, including airlines, it is important to prevent unauthorized contact with crated animals. Particularly with big cats, care must be taken that no spaces are available for them to reach out with their claws. Likewise, some form of fabric covering (such as burlap, metal window screen or shade cloth) over vents is recommended to prevent foreign objects being introduced to the crate. Padlocks are necessary on every door. Be certain to include keys in the envelope containing the animal's shipment paperwork.

The following diagrams and photographs (courtesy of Kurt Giesler, Assistant Curator of Mammals, Fort Worth Zoo) provide a good example of a safe design. They are not drawn to scale, but suggest materials and dimensions.

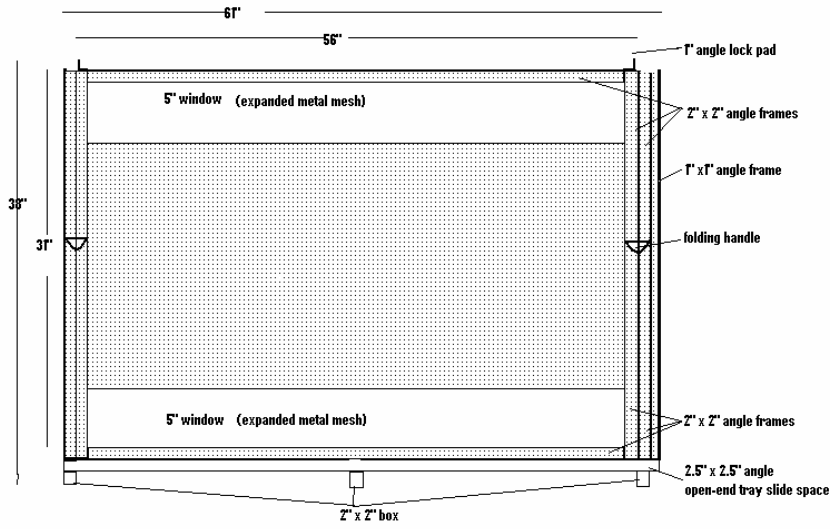

Outside dimensions: 61"L x 33"W x 38"H
Inside Dimensions: 56"L x 29"W x 31"H

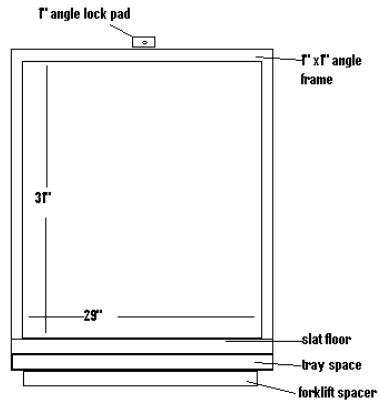

CRATE END VIEW

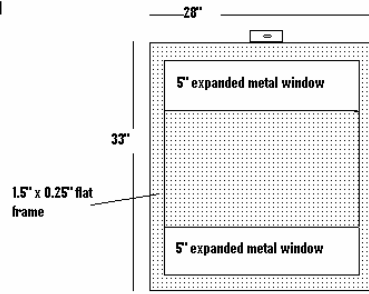

COVER DOOR

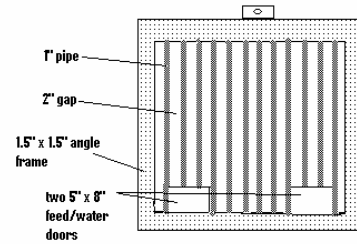

PIPE DOOR

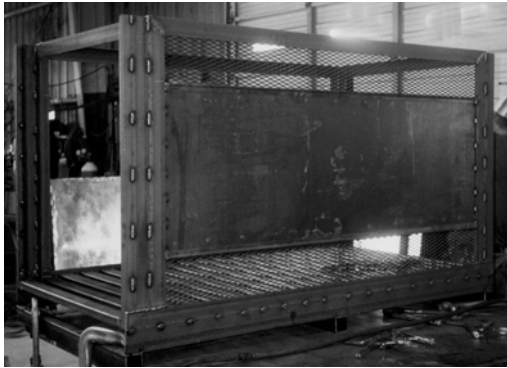
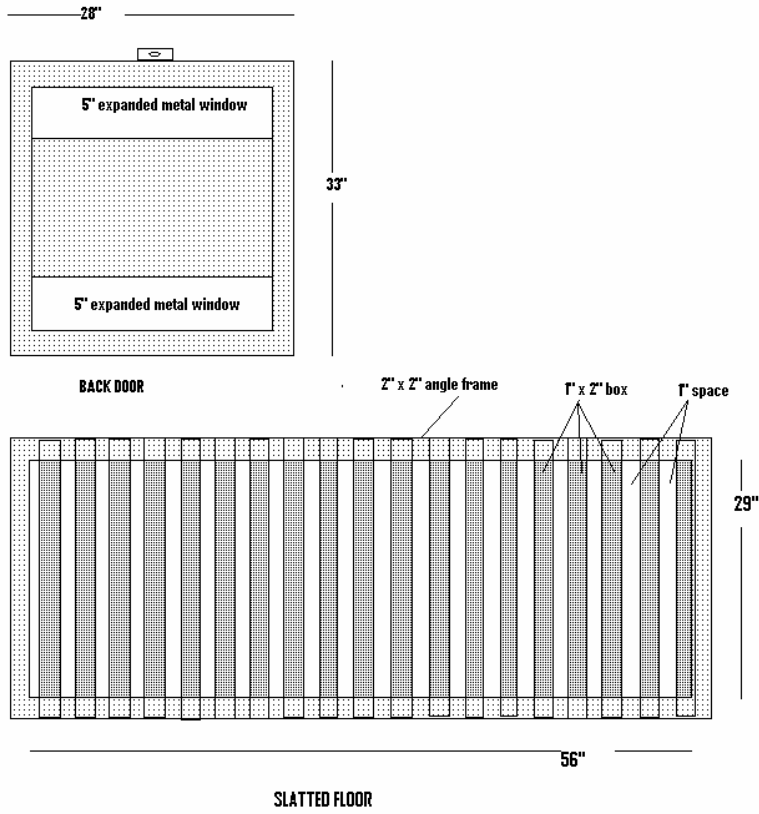

Management of Reproduction

Rebecca Spindler, Ph.D., Smithsonian National Zoological Park, Conservation & Research Center
 Stacey Johnson, Fort Worth Zoo

Zoos have held jaguars for many years, but still, relatively little is known about the reproductive characteristics of this powerful, popular animal. The following is a summary of the published (and some unpublished) information available. Poor reproduction is reported in range country zoos compared with free-living jaguars and North American captive individuals. There is still a great deal to learn about reproduction and the factors that influence its success.

GENETICS

There is recent information on genetic status of jaguars throughout Mexico and Latin America. Mitochondrial DNA from 44 captive-held individuals (mostly of wild-born origin) suggests that there is less genetic diversity than found in ocelots and margays, but nonetheless significant gene flow within the jaguar as a species (Eizirik *et al.*, 1998; Johnson *et al.*, 1998; Johnson *et al.*, 1999; Eizirik *et al.*, 2001). These findings indicate recent speciation (~280,000 – 510,000 years ago). Eizirik *et al.* (Eizirik *et al.*, 2001) recognized up to four phylogeographically isolated populations (Mexico and Guatemala, southern Central America, northern South America [north of the Amazon], and southern South America [south of the Amazon]). However, there was insufficient genetic distinction to designate subspeciation. There is a need to add more individuals to this database. These authors have advocated developing coordinated wild and captive management plans to avoid gene flow across these geographic barriers for the time-being, particularly between the southern and northern South American populations (Eizirik *et al.*, 2001). The SSP manages the jaguar population as a single species.

FEMALE REPRODUCTION

The most accurate method of characterizing female reproductive activity is through a longitudinal assessment of ovarian hormones. This evaluation can be conducted non-invasively by analyzing steroid metabolites excreted in feces. Fecal samples can be collected and ovarian (estrogen and progesterone) and adrenal (corticoid – as an index of stress) steroid metabolites analyzed. This data is most useful if data on behavioral, environmental and nutritional changes of the jaguar is taken throughout the evaluation period. A protocol is attached which describes the procedure for labeling and sending fecal samples to the National Zoo for analysis, other zoos may have slightly different protocols.

Puberty and Estrus

Females reach sexual maturity between the ages of 12 and 24 months. Estrus cycle is 37 days and estrus length is 6-17 days (Wildt *et al.*, 1998). Estrus can be detected by behavioral cues, such as lordosis, flehmen, vocalization, rolling and increased scent marking. Hormone levels can be detected non-invasively by the collection and analysis of fecal and urine for estrogen and progesterone metabolite concentrations (Brown *et al.*, 2001).

Seasonality

Free-living jaguars have been reported to reproduce year-round (Ewer, 1973), but may increase between March and June in the Southern Pantanal (Quigley and Crawshaw, 2001), indicating that mating most often occurs between December and March, coinciding with the receding of floodwaters, and greater availability of prey. It is not known if any seasonality is maintained in captivity where food availability and/or environment are controlled or if individuals display the same seasonal activity when moved to a different latitude.

MALE REPRODUCTION

Semen collection under anesthesia is an accurate method of gaining information on male fertility. As with all anesthetic events, food and water should be withheld for 12 hours before anesthesia induction. Some anesthesia protocols will increase the chances of urine contamination in semen samples due to relaxation of the bladder. The recommended anesthetic for use in jaguars for semen collection is Telazol, 6-8 mg/kg. Supplementation with ketamine is acceptable, but isoflurane increases chances of urine contamination, and should be delayed until after semen collection.

Brief description of semen evaluation

After reaching a surgical plane of anesthesia, each testis is measured as previously described (Howard, 1993), and a combined testicular volume calculated. The penis is extruded from its sheath and examined for the presence of spines (scale of 1-3, 3 = most prominent spines (Swanson *et al.*, 1995; Morato *et al.*, 2001)). Sperm is collected and evaluated by measuring: 1) semen volume, sperm count, motility and forward progressive status; 2) proportions of normal and abnormal sperm forms, all via phase microscopy (630 x) (Howard *et al.*, 1990) and 3) acrosomal integrity using the rose bengal/fast green stain (Pope *et al.*, 1991).

Semen characteristics

Males generally are sexually mature at the age of 24 -36 months. Sperm can be collected by electroejaculation (Morato *et al.*, 1999; Morato *et al.*, 2001). Semen is usually very dilute (~5 x 10⁶/ml) but large volumes are generally recovered (up to 20 ml) (Swanson *et al.*, 1995; Morato *et al.*, 2001; Morato *et al.*, 2003). Jaguars are normospermic (average ~65% normal) and survive cryopreservation relatively well (Morato *et al.*, 2003). Reproductive traits of Latin American captive males (i.e., sperm concentration, motility and morphology) have been found to be inferior to counterparts living in North American zoos (Swanson *et al.*, 1995) and freshly captured conspecifics (Morato *et al.*, 2001). Differences were unrelated to seasonal or weather factors, but appeared to be associated with poor health and nutrition in the *ex situ* population (Swanson *et al.*, 1995; Morato *et al.*, 1999; Morato *et al.*, 2001).

Seasonality

Males may show a slight seasonality in androgen levels throughout the year. Like the females, reproductive hormones appear to increase during the receding of the floodwaters, and are probably linked to increased abundance of prey (Morato *et al.*, in press).

BREEDING

Pairing

Valerie Flores, Gary Pavlik, Becky Volk, Stacey Johnson, Fort Worth Zoo.

The following describes a successful introduction and pairing at the Fort Worth Zoo.

1. Prior to initial introduction, the male and female jaguars were housed next to each other for a few days without visual contact. They could, however, hear and smell one another.
2. The jaguars alternated days on exhibit before we introduced them. This permitted each cat to be aware and investigate the presence of another jaguar nearby through olfactory recognition of marked spots and other deposits in the exhibit.
3. We waited until the female was in estrus to make the introduction. She vocalized, neck-rubbed on various parts of the exhibit, frequently rolled on her back and displayed lordosis posture at this time.
4. Four people were stationed around the exhibit with CO₂ fire extinguishers and water hoses in case the animals needed to be separated. Each was instructed to allow aggressive or defensive physical contact lasting up to 30 seconds before attempting to separate the cats. It was also recommended that aggression initiated by the female be allowed as long as no serious injuries occurred.
5. The female was released into the exhibit first. When she found a resting spot after her normal patrol of the exhibit, the male was introduced.
6. No aggression was shown by either cat, although the female dominated the encounter by baring teeth and swatting with forepaws when the male attempted to approach from her rear.
7. The jaguars were monitored continuously throughout their first day together on exhibit. Fire extinguishers were kept in easily accessible locations for the first week thereafter. The animals continued to be housed separately when off exhibit.
8. During the first week, keepers noted in daily reports that the male was receiving numerous superficial bite and scratch marks, although the female had none.
9. Copulation was first observed 13 days after introduction.
10. The female displayed estrous behavior lasting eight to nine days, beginning every four weeks.
11. The first indication of possible pregnancy occurred when normally obvious estrous behavior failed to occur in the fourth month after they had been together. As this jaguar's cycle had previously been very regular, a second skipped estrous behavior period led us to conclude that she was pregnant.

Assisted breeding

If natural mating is not an option because of behavioral incompatibility or location, assisted breeding techniques can be used to achieve recommended breeding. Generally, artificial insemination would be employed to inseminate females with sperm from recommended males that are aggressive, or are at a different facility (either nationally or internationally). Artificial insemination has not been successful in the jaguar as far as we know. The process requires semen collection (and possibly freezing) and administering female with exogenous hormones to induce ovulation and finally, females must be anesthetized for laparoscopic insemination (Howard *et al.*, 1992). If genetic material is required from individuals that cannot be imported, embryos can be produced *in situ*, cryopreserved, imported and implanted into generic females in the target country/population. Artificial insemination is routinely used as a meta-population tool in many species. Embryo transfer has been successful in several cat species (Donoghue *et al.*, 1990), but some basic information is still required before this should be attempted in the jaguar.

Pregnancy diagnosis

Confirmation of pregnancy can be obtained by ultrasound (requires anesthesia) or fecal and urine levels of progesterone by radioimmunoassay or enzyme-immunoassay.

HUSBANDRY DURING PREGNANCY AND REARING

Stacey Johnson, Fort Worth Zoo

Gestation period is generally 91-111 days and litter size is usually 1-4 cubs.

Information provided below is from one institution. Differences in institutional philosophy and facilities may dictate the use of other methods. Following is a protocol for maternal care and rearing of jaguars at the Fort Worth Zoo.

1. Condition dam to accept isolation and altered feeding regimen at least two weeks prior to the earliest due date.
2. Starting 10 to 14 days before the earliest due date, enclose dam's bedroom caging with plywood, from floor to about one foot from the ceiling. (The space is to allow ventilation and light.) Complete this enclosure in stages over a period of at least one week.
3. To establish a consistent routine, assign only one keeper to care for jaguars beginning no less than one week prior to earliest due date. Another recommended option would assign two keepers, providing alternate coverage to allow for days off or other absence. Only in emergencies will anyone else enter the jaguar night house after this time.
4. Construct a den box with at least five completely enclosed sides, and a threshold on the sixth side that will prevent cubs from immediately wandering. Ensure that significant effort would be required by the jaguar to dismantle this den box. As on any animal enclosure, leave no sharp points or edges anywhere the animal might reach them. This should be done at least two days prior to the earliest due date to allow for acclimation and so as not to be caught off-guard by an

early birth. Introduce bedding (e.g. hay or shavings) to allow the dam to hide cubs if she is nervous. However, monitor closely for ingestion of bedding and prepare to remove it if necessary.

5. During the week before parturition and for at least the first week after, monitor and severely limit foot and vehicle traffic around the den building.
6. After parturition, visually check the health of the cub(s) with as little invasion of the cats' space as possible. Video monitoring is preferred, but if that is impossible it is recommended to wait 24 to 36 hours after birth to physically enter the den.
7. Disable and empty automatic water sources. Supply drinking water in areas inaccessible to cubs, or in containers small enough not to be a drowning hazard to them. This poses a risk of dehydration to the dam. Observe her for defecation and urination regularly. Ensure that her drinking water supply is adequate.
8. Food need not be offered on the date of parturition, but when it is offered the diet should be placed to easily retrieve any uneaten portion.
9. If cubs seem healthy and cared-for by the mother, do not enter the den area/bedroom for the first three days. Manage the dam's food and water intake by shifting her outside for exercise and feeding.
10. On day three, request a veterinary examination and weigh the cubs. It is important to use gloves and to rub jaguar feces or soiled hay on them to mask any unfamiliar scent. Identify the sex of the animal(s) and check for normal physical development and condition. If possible, permanently identify the cubs with microchip transponders. Weigh the cubs weekly for as long as it is practical.
11. Clean the bedroom/den area only as absolutely necessary during the first two weeks of the cubs' life.
12. At two weeks, begin reintroducing all normal keeper staff to the jaguar areas.
13. At three weeks, begin routine daily cleaning of the bedroom but take care not to establish a wet environment.
14. Also at three weeks, begin giving the dam access to the exercise yard throughout the day – depending on outdoor weather and temperature conditions.
15. Between four and six weeks of age, under veterinary care, begin routine vaccination series. Minimize the number of veterinary staff and associated sensory cues (smells, sounds, etc.). Boosters will be given every four weeks through a series of three injections.
16. At four weeks begin introducing novel items to the holding yard and den that will stimulate the cubs to varying conditions. Use extreme caution in choosing items that are not a potential hazard to cubs.

17. At around two weeks after the second vaccination, or when she appears completely comfortable, allow the dam daily access to the exhibit and den area. If she chooses to move the cubs, simply monitor the activity without forcing any behavior.
18. After the first round of vaccinations, and for as long as is practical, separate the cubs from the dam for at least one hour each day and handle the cubs. Gradually introduce all the animal staff that will be involved in their long-term management and care. The purpose of this activity is to familiarize the animals with human activity and contact, NOT to tame them.
19. When cubs go on exhibit, begin training efforts to condition cubs to move between den area and exhibit.
20. Expect to go hands-off with the cubs by the time they are six months of age.

CONTRACEPTION

The SSP recommends separating cats as the primary method of contraception. For chemical contraception, MGA implants have most often been used in jaguars, but Linda Munson has evidence that incidence of cancer in jaguars is correlated with this contraceptive. Currently, there is no recommended contraception other than vasectomy, spaying or separation.

POST-MORTEM

Reproductive management does not end with the life of the animal. Many of the jaguars in zoos worldwide are valuable, but even when individuals are not considered valuable, their reproductive tracts can provide essential information to help us determine reproductive requirements of the jaguar. Below is a protocol for recovery and handling of jaguar reproductive tracts post-mortem. It is very important that these protocols are meshed with the need for pathology work.

PROTOCOL FOR LABELING AND SENDING FECAL SAMPLES FOR FECAL STEROID ANALYSIS

Labeling and sending fecal samples

Contact Janine Brown or Rebecca Spindler at Smithsonian National Zoological Park, Conservation & Research Center (jbrown@crc.si.edu and rspindler@crc.si.edu) to discuss schedules and cost of tests. Fecal samples should be collected every other day and placed in Ziploc baggies, with a clear label including animal ID (name and studbook number), date of collection, and a.m. or p.m. collection. Baggies and labels can be obtained from CRC. Samples should be frozen immediately and kept frozen until sent. Samples will be processed and analyzed for steroid metabolites using procedures validated for other felid species (Brown *et al.*, 1994). If at all possible, samples should be dried in a lyophilizer, or oven at 70°C for 3 days (Terio *et al.*, 2002). Once dried, samples can remain in a dry place at room temperature. Before drying, all samples should remain frozen, and should be shipped on dry ice.

PROTOCOLS FOR FELID REPRODUCTIVE TISSUE PATHOLOGY AND GENE RESCUE

Please note that pathology protocols have not changed. For any felids in contraception studies or with any apparent lesions of the reproductive tissue, tracts should still be fixed in 10% formalin, accompanied by form for the contraceptive studies and shipped to:

Dr. Linda Munson - University of California, Dept. VM-PMI, 1126 Haring Hall, 1 Shields Avenue, Davis, CA 95616, (530) 754-7567, email: lmunson@ucdavis.edu

For remaining reproductive tissues, please contact Rebecca Spindler. Skin samples, ovaries and testes should be prepared and sent out for gamete rescue as soon as possible so that the genes of that individual can be recovered. The following flow chart is provided to determine where reproductive and genetic material should be sent.

Testes for Gamete Retrieval:

- 1) Contact the person below, to advise them of gonadal material, and to receive Fed-Ex account number to send tracts (Conservation & Research Center).
- 2) Remove the testis, epididymis and vas deferens under sterile conditions, ligate the vas deferens using suture material to avoid fluid leakage.
- 3) Place tract in one layer of gauze moistened with sterile saline or PBS (NOT FORMALIN), in a sealed tube or water proof bag. Refrigerate until the tract is ready to be transported (express delivery overnight) in a Styrofoam container on a cold pack or on ice.
- 4) Label each tube or bag with the date and time of death or testis removal.
- 5) Testes should arrive within 48 hours for recovery of viable sperm.
- 6) A full thickness skin sample (~1 cubic centimeter) should be recovered from the medial thigh area. The fur should be clipped and the skin cleaned with alternate iodine / alcohol scrubs, followed by a final wipe with alcohol. Allow the alcohol to evaporate before obtaining the skin sample. Place the skin sample in a screw-top tube of saline or PBS (NOT FORMALIN) and refrigerate until shipment.
- 7) Animal gender, ARKS accession or studbook number and a contact person and number should be included to ensure maximum genetic value is obtained from these gametes

Contact: Rebecca Spindler – Conservation & Research Center, 1500 Remount Road, Front Royal VA 22630; tel: (540) 635 6594, fax: (540) 635 6506, email: rspindler@crc.si.edu

Ovaries for Gamete Retrieval:

- 1) Contact person below, to advise them of gonadal material, and to receive Fed-Ex account number to send tracts (Conservation & Research Center).
- 2) Place ovaries in one layer of gauze moistened with sterile saline or PBS (NOT FORMALIN), in a sealed tube or water proof bag layer of damp gauze, in a tube or water proof bag. Refrigerate until the tract is ready to be transported (express delivery overnight) in a Styrofoam container on a cold pack or on ice.
- 3) Label each tube or bag with the date and time of death and ovary removal.
- 4) Ovaries should arrive within 24 hours for recovery of viable oocytes.
- 5) A full thickness skin sample (~1 cubic centimeter) should be recovered from the medial thigh area. The fur should be clipped and the skin cleaned with alternate iodine / alcohol scrubs, followed by a final wipe with alcohol. Allow the alcohol to evaporate before obtaining the skin sample. Place the skin sample in a screw-top tube of saline or PBS (NOT FORMALIN) and refrigerate until shipment.
- 6) Animal gender, ARKS accession or studbook number and a contact person and number should be included to ensure maximum genetic value is obtained from these gametes.

Contact : Rebecca Spindler - Conservation & Research Center, 1500 Remount Rd, Front Royal VA 22630 tel: 540 635 6594, fax: 540 635 6506, e-mail: rspindler@crc.si.edu

References:

- Brown J, Graham L, Wielebnowski N, Swanson W, Wildt D and Howard J (2001) Understanding the basic reproductive biology of wild felids by monitoring of faecal steroids *Journal of Reproduction and Fertility Supplement* 57 71-82
- Brown JL, Wasser SK, Wildt DE and Graham LH (1994) Comparative aspects of steroid hormone metabolism and ovarian activity in felids, measured noninvasively in feces *Biology of Reproduction* 51 776-786
- Donoghue AM, Johnston LA, Seal US, Armstrong DL, Tilson RL, Wolf P, Petrini K, Simmons LG, Gross T and Wildt DE (1990) In vitro fertilization and embryo development in vitro and in vivo in the tiger (*Panthera tigris*) *Biology of Reproduction* 43 733-744
- Eizirik E, Bonatto S, Johnson W, Jr. PC, Vie J, Brousset D, O'Brien S and Salzano F (1998) Phylogeographic patterns and mitochondrial DNA control region evolution in two Neotropical cats (*Mammalia, Felidae*) *Journal of Molecular Evolution* 47 613 -624
- Eizirik E, Kim J, Menotti-Raymond M, Crawshaw P, O'Brien S and Johnson W (2001) Phylogeography, population history and conservation genetics of jaguars (*Panthera onca*, Mammalia, Felidae) *Molecular Ecology* 10 65-79

- Howard J (1993) Semen collection and analysis in non-domestic carnivores. In *Zoo and Wild Animal Medicine III* pp 390-399 Ed M Fowler. WB Saunders Co, Philadelphia
- Howard JG, Brown JL, Bush M and Wildt DE (1990) Teratospermic and normospermic domestic cats: ejaculate traits, pituitary-gonadal hormones and improvement of spermatozoal motility and morphology after swim-up processing *Journal of Andrology* 11 204-215
- Howard JG, Donoghue AM, Barone MA, Goodrowe KL, Blumer ES, Snodgrass K, Starnes D, Tucker M, Bush M and Wildt DE (1992) Successful induction of ovarian activity and laparoscopic intrauterine artificial insemination in the cheetah (*Acinonyx jubatus*) *Journal of Zoo and Wildlife Medicine* 23 288-300
- Johnson W, Culver M, Iriarte A, Eizirik E, Seymour K and O'Brien S (1998) Tracking the evolution of the elusive Andean Mountain Cat (*Oreailurus jacobita*) from mitochondrial DNA *Journal of Heredity* 89 227-232
- Johnson W, Pecon-Slattery J, Eizirik E, Kim J, Raymond M, Bonacic C, Cambre R, Crawshaw P, Nunes A, Seuanez H, Moreira M, Seymour K, Simon F, Swanson W and O'Brien S (1999) Disparate phylogeographic patterns of mitochondrial DNA variation in four closely related South American small cat species *Molecular Ecology* 8 79-94
- Morato R, Guimarães M, Ferreira F, Verreschi I and Barnabe R (1999) Reproductive characteristics of captive male jaguars (*Panthera onca*) *Brazilian Journal of Veterinary Research and Animal Science* 36
- Morato R, Conforti V, Azevedo F, Jacomo A, Silveira L, Sana D, Nunes A, Guimaraes M and Barnabe R (2001) Comparative analyses of ejaculate-endocrine characteristics of free-living versus captive jaguars (*Panthera onca*) *Journal of Reproduction and Fertility* 122 745-751
- Morato R, Wildt D and Spindler R (2003) Influence of medium-term storage on cat sperm prior to cryopreservation *Theriogenology* in press
- Morato R, Verreschi I, Guimarães M, Cassaro K, Pessuti C and Barnabe R (in press) Seasonal variation in the endocrine-testicular function of captive-jaguars (*Panthera onca*) *Theriogenology*
- Pope C, Zhang Y and Dresser B (1991) A simple staining method for evaluating acrosomal status of cat spermatozoa *Journal of Zoo and Wildlife Medicine* 22 87-95
- Quigley H and Crawshaw PJ (2001) Reproduction, growth and dispersal of jaguars in the Pantanal region of Brazil. In *The jaguar in the new millennium* pp Ed R Medelin, K Redford, Q Howard and A Rabinowitz. UNAM, Mexico City
- Swanson W, Wildt D, Cambre R, Citino S, Quigley K, Brousset D, Morais R, Moreira N, O'Brien S and Johnson W (1995) Reproductive survey of endemic felid species in Latin American zoos: male

reproductive status and implications for conservation *Proceedings of the American Association of Zoo Veterinarians* 1 374-380

Terio K, Brown J, Moreland R and Munson L (2002) Comparison of different drying and storage methods on quantifiable concentrations of fecal steroids in the cheetah *Zoo Biology* 21 215-222

Wildt DE, Brown JL and Swanson WF (1998) Reproduction in Cats. In *Encyclopedia of reproduction* pp 497-510 Ed E Knobil and J Neill. Academic Press, New York

REPRODUCTIVE DISEASES OF JAGUARS

L. Munson

Jaguars appear to be uniquely predisposed to develop gynecological cancers. High prevalences of ovarian, endometrial and mammary gland cancers have been identified in captive jaguars through the AZA Contraceptive Advisory Group Contraceptive Health Surveillance program. Although other felids also develop mammary gland cancer and endometrial cancer, the risk is considerably higher in jaguars. Also, ovarian cancer has only been found to date in jaguars and affects more than 50% of the aged population. This combination of ovarian, uterine, and mammary cancers is linked to a genetic mutation in humans, which is of concern for the Jaguar SSP. To address these concerns, we have been determining if similar genetic mutations are present in the jaguar population. For these studies, we need frozen tissues from both affected and unaffected jaguars and complete (intact) formalin- fixed reproductive tracts from all jaguars that are ovariohysterectomized (spayed) or that die (see appendices for forms). Frozen tissues for genetic analyses should include small samples of any tumor, as well as heart, spleen, and skeletal muscle.

PATHOLOGY SURVEILLANCE

Important diseases affecting population viability are detected or confirmed through performing a complete necropsy and comprehensive histopathology on individual animals and then collecting all information through the SSP veterinarian and pathologist. Currently, the principal concern in jaguars is the high prevalence of cancers, particularly those of the reproductive tract and mammary gland. However, vigilance is important if emerging diseases are to be detected in the population. Currently there are no funds available for a formal pathology survey by the SSP pathologist. What the SSP is recommending is that: 1) a complete necropsy be performed on any animal that dies, 2) a complete set of tissue samples be fixed and archived for the SSP, 3) the reproductive tract and selected frozen samples be sent to the SSP Pathologist (L. Munson), 4) each zoo veterinarian decide what tissue samples to take and submit for histopathology, and 5) the final necropsy report be submitted to the SSP veterinarian.

Protocols for submitting the reproductive tract are in Appendix ?.

A necropsy protocol including a worksheet and list of tissues to sample is in Appendix ?

REFERENCE FOR BIBLIOGRAPHY (ABSTRACT ONLY)

Munson L. 1994 A high prevalence of ovarian papillary cystadenocarcinomas in jaguars (*Panthera onca*). *Vet Pathol.* 31:604.

A HIGH PREVALENCE OF OVARIAN PAPILLARY CYSTADENOCARCINOMAS IN JAGUARS (*Panthera onca*)

Linda Munson, DVM, University of California

A high prevalence of papillary cystadenocarcinomas was noted in jaguar ovaries examined during a survey of reproductive lesions of captive wild felids. Ovaries from 12 jaguars were examined, and 9 of 12 had papillary cystadenocarcinomas in various stages of progression. The neoplasms consisted of multiloculated cysts containing clear fluid and intraluminal papillary projections. All neoplasms invaded the tunica albuginea and papillary projections were implanted on adjacent serosal surfaces. Histologically, all neoplasms were composed of cuboidal to columnar, deeply basophilic epithelial cells that lined cystic spaces and covered papillary projections. Cystic areas of the neoplasms were interspersed with regions of dense, compressed papillary structures without cyst formation. Jaguars with ovarian cancer were aged (mean = 17.25; range 12 - 24 yr), and all were from separate zoos. Only 5 of 9 had been contracepted with progestins. Endometrial carcinomas also were prevalent in jaguars (20 % of jaguars in the study), but only in progestin-contracepted jaguars. No other felid (N = 66) of 20 species had ovarian cystadenocarcinoma. These findings suggest that jaguars are uniquely predisposed to develop ovarian cancer, and may also be at higher risk to develop endometrial cancer.

MEMORANDUM

TO: ZOOLOGICAL VETERINARIANS AND MAMMAL CURATORS

FROM: Dr. Linda Munson
Pathologist Advisor for AZA Contraceptive Advisory Group
University of California- Davis
School of Veterinary Medicine
Department of Pathology, Microbiology, and Immunology
One Shields Avenue
Davis, California 95616 U.S.A.
Phone: 530-754-7963; FAX: 530-752-3349, Email: lmunson@ucdavis.edu

DATE: March 6, 2003

SUBJECT: Update on Contraceptive Health Surveillance Center

The AZA Contraceptive Advisory Group is continuing to survey the reproductive health of animals on contraceptives through a pathology survey of the reproductive tracts of *all mammalian species regardless of contraceptive history*. Please submit any available reproductive tract for this survey.

SAMPLES: Intact, formalin-fixed reproductive tracts (uterus, ovaries and mammary gland if possible) obtained from necropsy or ovariectomy of any female mammal.

FOR JAGUARS: Please freeze small samples of ovary and uterus (and if a necropsy, also freeze spleen, heart muscle, and skeletal muscle) before fixing the tract.

FIXATION: Make a *small* incision into the body of the uterus (primates) or into each horn (bicornuate uteri) and then immerse in buffered formalin for at least 72 hours (ratio of tissue to formalin = 1:10).

SHIPPING: Wrap fixed tracts in formalin-soaked paper towels, enclose in a leak-proof plastic container and ship by ground US mail (Federal Express is not necessary) to the above address. Several mailing labels are enclosed for convenience. For reproductive tracts that are too large to fix whole and ship (elephants, rhinoceros, etc), representative sections may be cut according to the attached protocol.

FOR JAGUARS: Please ship frozen tissues separately from fixed tissues. Frozen tissues should be shipped on dry ice by courier (overnight) mail.

SURVEY FORM: It is important that you also provide the information requested on the enclosed form. We will not be able to include your case without this information. This provides valuable data on the duration and dose of any contraceptive treatment and the effects of age and parity on the lesions.

When the data are collated, I will send a brief report on the reproductive tract to you and will be certain to acknowledge your contribution in any publication resulting from this survey.

I thank you in advance for contributing to this survey. Your submissions will be used to develop safer methods of contraception in zoo animals.

AZA CONTRACEPTIVE PATHOLOGY SURVEY

If no information is available please indicate in the spaces provided

Submitting veterinarian _____

Institution _____

Address _____

Animal ID: Name _____ ISIS _____ ZOO ID _____ SB# _____

Species _____ Date of birth _____ Weight _____

Date when uterus was obtained _____ Was it death or spay? _____

Breeding history at your zoo:

Has this animal been cycling? Y N

Has this animal been bred? Y N

Dates of pregnancies? _____

Has this animal spent her entire reproductive life at your zoo? Y N

If no: sites of previous residence: _____

Previous ID numbers (if known): _____

FOR MELENGESTROL IMPLANTS (MGA):

Has this animal shown estrus when implanted? Y N

IMPLANT #	IMPLANT WEIGHT	ANIMAL WEIGHT	DATE INSERTED	DATE REMOVED
_____	_____	_____	_____	_____
_____	_____	_____	_____	_____
_____	_____	_____	_____	_____
_____	_____	_____	_____	_____
_____	_____	_____	_____	_____

OTHER CONTRACEPTIVES

Type: _____

Dose of contraceptive _____

Dates of treatment: _____

HAS THIS ANIMAL HAD OTHER HEALTH PROBLEMS THAT MAY AFFECT REPRODUCTION?

Dr. Linda Munson
University of California
VM-PMI
1126 Haring Hall
1 Shields Ave
Davis, CA 95616

Dr. Linda Munson
University of California
VM-PMI
1126 Haring Hall
1 Shields Ave
Davis, CA 95616

Dr. Linda Munson
University of California
VM-PMI
1126 Haring Hall
1 Shields Ave
Davis, CA 95616

Dr. Linda Munson
University of California
VM-PMI
1126 Haring Hall
1 Shields Ave
Davis, CA 95616

Dr. Linda Munson
University of California
VM-PMI
1126 Haring Hall
1 Shields Ave
Davis, CA 95616

Dr. Linda Munson
University of California
VM-PMI
1126 Haring Hall
1 Shields Ave
Davis, CA 95616

Dr. Linda Munson
University of California
VM-PMI
1126 Haring Hall
1 Shields Ave
Davis, CA 95616

Dr. Linda Munson
University of California
VM-PMI
1126 Haring Hall
1 Shields Ave
Davis, CA 95616

Dr. Linda Munson
University of California
VM-PMI
1126 Haring Hall
1 Shields Ave
Davis, CA 95616

Dr. Linda Munson
University of California
VM-PMI
1126 Haring Hall
1 Shields Ave
Davis, CA 95616

March 2003

**American Zoo and Aquarium Association
JAGUAR SSP NECROPSY PROTOCOL**

INSTITUTION/OWNER

ADDRESS

JAGUAR NAME OR ID # _____ STUD BOOK # _____ SEX

BIRTH DATE/AGE _____ WEIGHT

DATE OF DEATH _____ DATE OF NECROPSY

HISTORY: (briefly summarize clinical signs, circumstances of death):

SHIPPING TISSUES: PLEASE OBTAIN PROPER CITES AND EXPORT PERMITS BEFORE SHIPPING TISSUES. SHIP FROZEN TISSUES IN SEPARATE CONTAINER THAN FIXED TISSUES.

After 72 hrs in fixative, ship tissues in a leak-proof container in adequate formalin to keep tissues moist. Frozen tissues should be shipped with adequate dry ice to keep frozen for 72 hrs. Tissues can be shipped by U.S. Mail or by courier to:

Dr. Linda Munson
Dept. VM-PMI
1126 Haring Hall
1 Shields Ave
Davis, CA 95616
USA

PHONE # 530-754-7567
FAX # 530-752-3349
E-MAIL: lmunson@ucdavis.edu

GROSS EXAMINATION WORKSHEET

***** PLEASE PROVIDE A COPY OF THE GROSS NECROPSY REPORT IF AVAILABLE *****

PROSECTOR:

GENERAL CONDITION: (Nutritional condition, physical condition)

Neonates: examine for malformations (cleft palate, deformed limbs, etc)

SKIN: (Including pinna, feet)

MUSCULOSKELETAL SYSTEM: (Bones, joints, muscles)

BODY CAVITIES: (Fat stores, abnormal fluids)

Neonates: assess hydration (tissue moistness)

HEMOLYMPHATIC: (Spleen, lymph nodes, thymus)

RESPIRATORY SYSTEM: (Nasal cavity, larynx, trachea, lungs, regional lymph nodes)

CARDIOVASCULAR SYSTEM: (Heart, pericardium, great vessels)

DIGESTIVE SYSTEM: (Mouth, teeth, esophagus, stomach, intestines, liver, pancreas, mesenteric lymph nodes). **Neonates:** is milk present in stomach?

URINARY SYSTEM: (Kidneys, ureters, urinary bladder, urethra)

REPRODUCTIVE SYSTEM: (Testis/ovary, uterus, vagina, penis, prepuce, prostate, mammary glands, placenta)

ENDOCRINE SYSTEM: (Adrenals, thyroid, parathyroids, pituitary)

NERVOUS SYSTEM: (Brain, spinal cord, peripheral nerves)

SENSORY ORGANS (Eyes, ears)

PRELIMINARY DIAGNOSES:

LABORATORY STUDIES:(List bacterial and viral cultures submitted and results, if available)

***** **FEMALE REPRODUCTIVE TRACT** *****

Captive jaguars have an unusually high prevalence of cancers of the ovary, uterus, and mammary gland. So it is critical that the entire female reproductive tract be included in the tissues submitted. First freeze a small piece of any tumor of the reproductive tract. If no tumor is evident, then freeze a small section of ovary and a cross section of uterus for genetic analyses. Include these frozen tissues with the frozen tissues requested below.

FIXED TISSUE CHECK LIST

Preserve the following tissues in 10 % buffered formalin at a ratio of 1 part tissue to 10 parts formalin. Tissues should be no thicker than 1 cm. INCLUDE SECTIONS OF ALL LESIONS AND SAMPLES OF ALL TISSUES LISTED BELOW.

- ___ **3 Blood smears**
- ___ **Salivary gland**
 - ___ **Oral/pharyngeal mucosa and tonsil** -include areas with erosions, ulcers or proliferative lesions.
- ___ **Tongue** - cross section near tip including both mucosal surfaces. Check under tongue for lesions.
- ___ **Lung** - sections from several lobes including a major bronchus
- ___ **Trachea**
- ___ **Thyroid/parathyroids** - leave intact.
- ___ **Lymph nodes** - cervical, mediastinal, bronchial, mesenteric and lumbar. Cut transversely.
- ___ **Thymus**
- ___ **Heart** - longitudinal sections including atrium, ventricle and valves from right and left sides.
- ___ **Liver** - sections from 3 lobes, including gall bladder
- ___ **Spleen** - Cross sections including capsule.
- ___ **GI Tract** - 3 cm long sections of:
 - ___ **Esophagus**
 - ___ **Stomach** - multiple sections from cardia, fundus (body), and antrum of pylorus
 - ___ **Small intestines** - duodenum, jejunum, ileum
 - ___ **Large intestines** - cecum, colon
- ___ **Omentum** - ~3 cm square
- ___ **Pancreas** - representative sections from two areas including central ducts
- ___ **Adrenal** - entire gland with transverse incision.
- ___ **Kidney** -cortex and medulla from each kidney
- ___ **Urinary bladder, ureters, urethra** - cross section of bladder and 2 cm sections of ureter and urethra.
 - ___ **Reproductive tract** - Entire uterus and ovaries with longitudinal cuts into lumen of uterine horns.
- Both testes (transversely cut) with epididymis. Entire prostate, transversely cut.
- ___ **Mammary gland:** Any masses or cysts and sections of normal gland surrounding the nipple.
- ___ **Eye** - both eyes kept intact. Remove extraocular muscles and periorbital tissues.
- ___ **Brain** - cut longitudinally along midline. Submit entire brain (retain small part of

- frontal cortex frozen) and **pituitary gland**.
- **Spinal cord** (if neurologic disease) - sections from cervical, thoracic and lumbar cord.
 - **Diaphragm and Skeletal muscle** - cross section of thigh muscles
 - **Opened rib or longitudinally sectioned 1/2 femur** - marrow must be exposed for proper fixation
 - **Skin** - full thickness of abdominal skin, lip and ear pinna.
 - **Neonates: umbilical stump** - include surrounding tissues.

FROZEN TISSUES: Freeze a sample of lung, spleen, liver, lymph node, heart and skeletal muscle at (preferably) -70°C .

Environmental Enrichment

Christopher Law, Elmwood Park Zoo

ENRICHMENT GUIDELINES

In *Second Nature*, Shepherdson explains His definition of environmental enrichment “Environmental enrichment is an animal husbandry principle that seeks to enhance the quality of captive animal care by identifying and providing the environmental stimuli necessary for optimal psychological and physiological well-being.”

In Jaguars we can accomplish this in many different ways. One good rule is to encourage natural behaviors when possible. Because food, shelter and water are provided in captivity, the need to search for them is removed and psychological stimulation becomes an important component of animal management. The following is a basic guideline to help develop an environmental enrichment program for jaguars in captivity. Items should be given randomly to keep the animals interest. All items should have your managers and veterinarians approval.

1. **Night Holding:** A resting platform for each cat. Logs and stumps for scent marking and sharpening claws.
2. **Outside Exhibit:** Usually natural substrate is preferred such as grass or dirt (see husbandry section). Logs can be hung, attached or on the ground. There should be plenty of visual barriers for the animal to *feel* completely hidden from the public. The exhibit should have plenty of vertical perching for climbing with real or artificial logs, branches or rocks and various high nesting sights. The top of the cage should have plenty of natural coverage for shade and security. There should be at least one water source. Pools, ponds and streams are recommended for drinking, playing and cooling off.
3. **Novel Objects:** Objects such as boomer balls and cardboard boxes promote the natural stalk and pouncing behavior. Small logs can also be used on exhibits for a natural look.
4. **Natural Feeding:** “In order to provide opportunities to exhibit species-appropriate behaviors or otherwise enable animals to work for food, a number of enrichment items can be added to their outdoor or indoor enclosure and exhibits. It is recommended that large felids be offered edible (or other) items on an ongoing but random schedule in order to combat stereotypic behaviors such as pacing, hair pulling or self mutilation as well as to add more interest to their daily lives. Offering items at random is important as felids easily become desensitized; offering no enrichment on some days may be equally as effective. Food items from non-domestic stock should be frozen prior to freezing to kill any pathogens that might be present” (Shoemaker sec. 2.1.2.).

5. **Carcass Feeding:** “Because feeding live mammal or bird prey is not typically desirable or feasible, other techniques must be employed to provide appetitive or “hunting” opportunities for captive felids. An obvious technique is the feeding of humanely killed whole animals (e.g., rats, mice), gutted carcasses (e.g., chickens, rabbits), or carcass fragments (e.g., shanks of sheep or calf) (Law 1993). On receiving whole or partial carcasses, many cats exhibit all or part of the stalk-rush-kill sequence (Richardson 1982; Mellen, personal observation; Shepherdson, personal observation). In addition to the potential for improved psychological well-being (Lindburgh 1988), feeding whole carcasses may enhance physical well-being” (Mellen, Hayes, and Shepherdson pp. 195- 196).
6. **Olfactory:** Olfactory enrichment can encourage natural behaviors such as scent marking and exploratory behavior. Extracts such as spices and perfumes as well as different hunting scents and animal fur or feathers can be used. Always freeze items from other animals to remove parasites. One institution reports the use of urine from other species, centrifuged and examined for bacteria, as well. It is strongly recommended to obtain veterinary approval of any and all animal material before using it as enrichment.
7. **Training:** Positive reinforcement is a favorable form of training with jaguars. Behaviors learned can reduce the animals’ stress level when undergoing veterinary procedures. Training also provides physical and mental stimulation for the jaguar. Target training the animal to respond to cues for placement of its body in directed locations is one very useful behavior. Another behavior is crate training, in which the animal is gradually acclimated to feel safe and comfortable entering a transport crate. While training is not a natural instinctive behavior, a good training program can reduce stress and improve the animal’s quality of life. *Wild Mammals In Captivity*, edited by Kleiman, Allen, Thompson and Lumpkin, is a good resource for keepers interested in training. Another popular book illustrating positive reinforcement techniques is *Don’t Shoot the Dog*, by Karen Pryor.
8. **Auditory:** Auditory enrichment allows the jaguar to use their excellent hearing senses. Hearing possible prey animals or another jaguar can stimulate exploratory behavior. A radio can be stimulating or comforting for a jaguar.
9. **Social:** Social enrichment can decrease pacing and add a stimulating change to the day. Keeper interaction and visuals of other animals are two examples of social enrichment that can increase the complexity of a jaguar’s day.

ENRICHMENT SURVEY

The following are the results of an enrichment survey sent to fifty-one institutions that were exhibiting jaguars. We received responses from twenty-two of these facilities. The results are broken down and intended to be a resource to show what other institutions are doing and rate the success of each item. Each animal has its own individual demeanor, so the results here are by no means the definitive answer on how an animal will react. All the items submitted have

not necessarily been tested and what is fine for one jaguar can be problematic for another. Always have new items reviewed by your managers and veterinarians and follow your facilities safety guidelines.

1. **Exhibit Substrate:** Grass, dirt, sand, cement, wood chips and mulch.
2. **Outside Exhibit Furniture:** Waterfall, pond, stream, rocks, bamboo, trees (evergreen, mulberry, elm) swinging logs, shrubs, deadfall trees, tree limbs at different levels, rock den, concrete cave, timber platform, straw bed, rock ledge, brush pile, fire hose hammock, hot rock, gunite rock/trees, tree stumps, vines, plants (honey suckle, palms, butterfly bush, junipers), wood bridge over one-meter dry moat.
3. **Indoor Holding Area:** Wooden bench, shelves (wooden, gunite, plywood, metal, Corian®) pallets, kennel, den, vines, hide box, ropes, hanging cedar logs, hanging tire, wooden perching, pool (approximately one meter deep).
4. **List Food Items:** Feline diet, rats, crickets.
 Fish - live tilapia, tuna, herring, frozen salmon, live goldfish, trout, minnows, live red shiners, smelts, blood ice block, fish ice block (successful), frozen bouillon blocks, bagels soaked in blood, gelatin made with blood, blood ring with chicks, meatballs, boiled eggs, fetal calf, chunk horse meat, rabbit, quail, fresh blood, frozen streaks, frozen lamb, mice, fruit & vegetables, grapes.
 Chicken - Cooked chicken, necks, gizzard & hearts, liver, boneless chunks
 Bones: Venison, horse, cattle, frozen, beef tail, pork neck, horse shank, horse knuckle, mutton, cow leg.
 Venison - ground or whole.
 Horse - chunks of meat (training reward) liver, raw beef, pork hock.
 Presented - hidden, meat smeared on rocks, fish in pond, buckets meat training reward, hidden in PVC tubes, tree bags, perches in box with lid, tossed in on ropes.
5. **Social:**
 Alexandria - Female can see male. She can touch through baleen panel (She has bitten his ears through the panel).
 EPZ - Cage door the jaguars can be nose to nose (both have bitten each others ears).
 Ponies walk by.
 Rio Grande - Watches mountain lion, can see raccoon.
 Erie - Visuals of leopards, occasionally walks llamas or sheep in front of exhibit.
 Houston - We have two females and one male living together; they are constantly fluctuating in their social interactions. All three live together ninety percent of the time.
6. **Auditory:**
 Various animals throughout the Zoo.
 Tapes "rabbit in distress," deer calls, radio.
7. **Enrichment Problems:**

Chattanooga – stopped giving rawhides & bones due to excessive vomiting and diarrhea.

Caldwell - slight sneezing (spices).

St. Louis - female eats cloth, therefore, burlap sacks and rags are no longer given. She vomits after she eats them.

Bramble Park - Burlap: male has a habit of eating it when frozen or thawed meat is put in it & throws it back up. Keepers worry about the male hurting himself with a bowling ball.

Memphis - Diarrhea from thawed rabbit.

Lincoln Park - Only large shank bones are given to prevent him from crunching them.

Denver - Burlap bag strings have been ingested (bags must be removed promptly).

Little Rock - Male ingested some rope from safety net; this was removed promptly when the keepers found out.

EPZ - Impaction from chicken bone when female was kitten. She now ingests large bones & rats with no problem. Female ingests fur, cardboard, cloth. The cloth is no longer given.

Philadelphia - Jaguar is an older animal that vomits when given bone chunks, so types of food enrichment are limited.

Houston - Destroys any plastic softer than a five-gallon bucket. Male will sometimes eat paper.

The average rating for the chart is from 1 = no reaction to 5 = strong reaction.

NOVEL OBJECTS RATING CHART

Institutions	Novel objects	Average given	Average rating
21	Cardboard box	Monthly, bi-weekly, 4x a week	4
18	Boomer ball	Weekly, daily	3
6	Burlap bags	Weekly, bi-weekly, every 6 months	4
6	Bowling ball	Daily, 3x a week	3
6	Feather	Bi-weekly, weekly	3
6	Large barrel	Daily, weekly, yearly	4
4	Large boomer ball	Weekly	3
4	PVC	Monthly	3
4	Ice block	Monthly	3
4	Carpet tube	Monthly, bi-monthly	4
4	Pumpkin	Yearly, in fall	4
4	Papier maché prey animals	Yearly, every few months	5
3	Phone book	Occasionally, 2x a week, 2x a year	4
3	Beer keg	Weekly, monthly	4
3	Small boomer ball	Daily, weekly	4

3	Horse tail	Occasionally	4
2	Giant boomer ball	Bi-weekly	4
2	Bamboo stalks	Monthly	2, 4 with cinnamon
2	Spool	Daily, weekly	4
2	Sheep's wool	Monthly	3
2	Plastic pails	Occasionally	4
1	Boomer ball with holes for food placement	Weekly	5
1	Tractor tire	Weekly	5
1	Large "pill"	Monthly	4
1	Log	Monthly	4(likes to carry)
1	Lettuce head	Monthly	3
1	Pigs ears	Bi-weekly	3
1	Raw hides	Bi-weekly	3
1	Frozen fish juice	Occasionally	4
1	Beef noses/chins	Weekly	4
1	Camel Hair	4x a year	3
1	Plastic hour glass toy	Bi-weekly	4
1	Hay/wood wool	1-2x a month	3
1	Paper bags		5
1	Large heavy ball		2
1	Small barrel		2
1	Large plastic "spoolie"	Daily	5
1	Large rubber trash can	3-4x a week	5
1	Small rubber trash can	2-3x a week	4-5
1	Large soft plastic hose reel	Weekly	2-3
1	Large plastic trash can lids	1-2x a week	2-3
1	Plastic turkey feeder tray	1-2x a week	4-5
1	Bobbins	3x a week	2
1	Oranges	Once a week	2
1	Large Tub	Daily	5
1	5 gallon water jugs	Once a month	1
1	Guanaco hair	Once a month	3
1	5 gallon bucket		5
1	Tire	3x a week	4
1	Polyethylene bucket	4x a week	1

OLFACTORY RATING CHART

Institutions	Olfactory items	Average given	Average rating
16	Perfume / Cologne	Bi-weekly, weekly	3
9	Dry catnip	Bi-weekly	3
7	Cinnamon	Monthly, weekly	3
5	Garlic	Bi-weekly, weekly, quarterly	3
4	Nutmeg	Bi-monthly	3
4	Vanilla extract	Bi-monthly, every 6 months	3
4	Boxes / hay with scent	Weekly	5
3	Basil	Monthly, weekly	2
3	Doe scent	Bi-monthly	2
2	Fresh catnip	Weekly in summer	5
2	Oregano	Bi-weekly, weekly	3
2	Cloves	Bi-weekly, weekly	2
2	Paprika	Bi-weekly	4
2	Fox urine	2x a week	4
2	Mint extract	Bi-weekly	4
2	Toys from other exhibits	Weekly, monthly	3
1	Berry bliss (body mist)	Bi-weekly	3
1	Catnip oil	Every 2-3 weeks	4
1	Vinegar spray bottle with added scents	Once a week	3
1	Allspice	Bi-weekly	5
1	Sage	Bi-weekly	3
1	5 Chinese spice	Bi-monthly	5
1	Curry	Bi-monthly	5
1	Pumpkin pie spice	Bi-monthly	5
1	Onion	Bi-weekly	3
1	Fresh spices	Weekly	4
1	Fox scent	Occasionally	3
1	Fox, Mink, Deer, oil	Bi-weekly	4
1	Orange extracts	Bi-weekly	3
1	Anise extracts	Bi-weekly	3
1	Lemon extracts	Bi-monthly	5
1	Rum extracts	Bi-monthly	5
1	Chicken spray	2x a week	3
1	Skunk scent	Monthly	4
1	Fish herbs	When available	3
1	Bongo feces	Bi-monthly	1
1	Hoofstock feces	Monthly	5

1	Boomer ball from other cats	Weekly	5
1	New logs/stumps	Yearly	3
1	Logs from other animals	Bi-monthly	4
1	Explore Tiger cage	Weekly in winter	3
1	Lanolin	Bi-monthly	5
1	Deodorant	Bi-monthly	3
1	Leaves from hoofstock	Bi-monthly	5
1	Carnivores put in male exhibit	Monthly	3
1	Ginger	Weekly	1
1	Maned wolf scent	Once a week	3

I would like to thank the following Zoos for their participating in this survey:

Alexandria Zoo	Little Rock Zoo
Bowman Zoological Park	Louisville Zoo
Bramble Park Zoo	Memphis Zoo
Caldwell Zoo	Milwaukee County Zoo
Chattanooga Zoo	Oklahoma City Zoo
Denver Zoo	Philadelphia Zoo
Elmwood Park Zoo	Rio Grande Zoo
Erie Zoo	Sacramento Zoo
Houston Zoo	San Antonio Zoo
Jacksonville Zoo	Sedgwick County Zoo
Lee Richardson Zoo	St. Louis Zoo

REFERENCES

Kleiman, D. G., M. E. Allen, K.V. Thompson, and S. Lumpkin, eds. 1996 *Wild Mammals In Captivity: Principles and Techniques*. Chicago: University of Chicago Press.

Shepherdson, D. J., J. D. Mellen, and M. Hutchins, eds. 1998 *Second Nature: Environmental Enrichment for Captive Animals*. Washington and London: Smithsonian Institution Press.

Shoemaker, Alan H. 2003. *Zoo Standards for Keeping Large Felids in Captivity: AZA Minimum Husbandry Standards for Mammals*. Silver Springs: AZA Publishing. In Press, 2002.

Nutrition

Ann M. Ward, M.S., and Amy Hunt, M.S., Fort Worth Zoo

INTRODUCTION

Feeding jaguars in captivity is a combination of a nutritionally adequate diet and following good sanitation practices as recommended for meat/whole prey based diets. The nutrient content of all foods consumed, including enrichment items, contribute to the overall nutrient content of the diet. No studies have been completed to determine the specific nutrient requirements of jaguars. Consequently, until additional data become available, the domestic cat can serve as a model for most nutrient parameters.

NATURAL FEEDING HABITS/DIET COMPOSITION

Jaguars are strict carnivores that, by definition, consume only animal prey. Types of prey consumed by the jaguar are listed in detail by W.K. Baker in the Natural History, Behavior and Captive Management section of this handbook, and consist mainly of capybara, spectacled caiman, side-necked turtles, and collared peccary. Very little data is available for nutrient analysis of whole prey, however, vertebrate carcasses tend to be similar in nutrient composition across species such as rats, mice, and chicks (Allen, *et al.*, 1996). Water and fat may vary according to development state, reproductive condition and seasonal changes, and information on concentrations of fatty acids, vitamins D and K, water-soluble vitamins and essential amino acids is lacking (Allen, *et al.*, 1996, Dierenfeld, *et al.*, 2002). Consumption of viscera may help satisfy fat and vitamin requirements (Lindburg, 1988). In the wild, carnivores typically eat all or most of the prey they capture and kill, including bones, fat, and viscera. Given that all parts are consumed, including some bones or other calcified tissues, whole prey are commonly presumed to meet all nutrient requirements and maintain good oral hygiene (Dierenfeld, *et al.*, 2002). Wild cats have substantial energy expenditure in the capture and kill and may consume as much as 25 kilograms of meat at one feeding (Lindburg, 1988). Large feedings are often followed by a period of famine. Nutrient analysis of various whole prey items is given in Table 1.

GASTROINTESTINAL ANATOMY

The gastrointestinal tract of the cat is short and considered simple (Stevens and Hume, 1995). The cat has a stomach and short colon that is not compartmentalized. The small intestine is short as well, with limited area for nutrient absorption. This type of gastrointestinal tract is adapted to utilize a meat diet that does not require prolonged retention for digestion. Thus, cats have high energy, protein and ether extract digestibilities. In general crude protein and ether extract digestibilities average over 80% for captive large felids, including jaguars, as well as for domestic felids. (Morris, *et. al.*, 1974, Allen *et.al.*, 1995, Barbiers, 1982, Wynne, 1989, Hackenburger and Atkinson, 1983, NRC, 1986).

ESTIMATED NUTRIENT GUIDELINES

The estimated nutrient guidelines are based on the known nutrient requirements of the domestic cat reviewed by the National Research Council (NRC) in 1986 and nutrient profiles recommended for practical diets by the Association of American Feed Control Officials

(AAFCO) in 1994. The recommendations of the 1986 NRC are based on feeding purified or extremely bioavailable diets (supplying specific amino acids in place of an intact protein) and growth studies. The recommendations of the 1994 AAFCO document consider the bioavailability of ingredients commonly used in pet foods. Additionally, AAFCO suggests guidelines for animals at maintenance as well as growth. The combination of these documents is appropriate for feeding jaguars in captivity (Table 2). Nutrient considerations unique to strict carnivores are reviewed below. A complete review of all nutrients known to be required by the domestic cat is available in the 1986 NRC.

Energy Requirements

Extrapolation of the energy requirement for inactive and active cats (70-80 kcal/ kilograms body weight) is not appropriate for jaguars given that it does not consider differences in body size between the domestic cat (2-6 kilograms) and jaguars (56 kilograms). The Kleiber equation, calculating basal metabolic rate (BMR), multiplied by an activity factor better assesses differences in energy needs based on body weight ($BMR = 70 \times \text{body weight}^{0.75}$). This equation accounts for a decrease in energy needs per unit mass as an animal's size increases (Robbins, 1993). However, Kleiber does not account for differences in feeding strategy/foods naturally consumed. There appears to be an increase in energy needed for metabolism in animals maintaining greater muscle mass, consuming whole prey, readily digestible and available diets compared to animals consuming poorly digested, less available diets (McNab, 1989). This resulting equation for vertebrate consumers is $BMR = 91.8 \times \text{body weight}^{0.813}$. Further, carnivores that expend more energy due to their foraging style may require higher energy intakes than those with foraging strategies that minimize energy expenditure (Allen *et al*, 1995). In general, it is possible, due to similarities in foraging style, that jaguars can be compared to cheetahs and tigers, and not to lions.

In the absence of species-specific equations, general equations provided by Kleiber and McNab may provide a base from which to calculate diet amounts. However, these equations give an indication of energy needed to meet basal metabolism (the body at rest). They do not account for increases due to activity, physiological state, or for thermoregulation. It is common to apply a factor of 1.5-2 for maintenance and 3 or greater for early growth.

Energy Content of Foods

Protein, fat, and carbohydrate contribute to the energy content of a food. The energy content of foods can be expressed as gross energy (GE), digestible energy (DE), or metabolizable energy (ME). Gross energy is the resultant heat from the combustion of a food in a bomb calorimeter. Digestible energy is the GE minus energy lost in feces. Metabolizable energy is GE minus DE and energy lost in urine. Energy available for digestion and metabolism is determined by controlled studies where intake as well as, fecal and urine output is measured and analyzed. Digestible energy values can be converted to metabolizable energy values by the equation: $ME = 0.92(DE) - 2$ (Kendall *et al.*, 1983). Because these studies are difficult to conduct, often estimates of metabolizable energy are used, see below (AAFCO, 1994).

$ME \text{ (kcal/kg)} = 10((3.5 \times \text{crude protein}) + (8.5 \times \text{crude fat}) + (3.5 \times \text{carbohydrate or nitrogen free extract/NFE}))$

$$NFE = 100 - (\text{crude protein \%} + \text{crude fat\%} + \text{crude fiber\%} + \text{moisture\%} + \text{ash\%})$$

Protein

Cats require more total protein as well as higher levels of the amino acids methionine and cystine. [[One mgmt group member asked for additional information regarding what needs the higher levels of methionine and cystine fulfill.]] When faced with starvation or low protein diets, cats do not have the ability to conserve nitrogen. Thus, they have a high obligatory nitrogen loss due to reduced capacity to regulate enzymes critical to this process (Morris and Rogers, 1983). Methionine and cystine can serve as precursor for the amino acid taurine but cannot offset the cat's unique need for taurine in the diet (NRC 1986). Additionally, cats are more sensitive to arginine deficiency. Other mammals, through arginine synthesis, can meet needs for maintenance while the cat requires dietary arginine for both maintenance and growth (Morris and Rogers, 1983).

Carbohydrates

The strictly carnivorous nature of a cat's diet results in low carbohydrate consumption. Glucose is the main carbohydrate that serves as an energy source for tissues. In the cat, glucose can be derived from protein and fat through glucogenic pathways (Rogers and Morris, 1983). Fat furnishes glycerol while protein provides glucogenic amino acids. Consequently it is not surprising that cats do not have a high level of activity of the glycolytic enzyme, glucokinase, in the liver (Rogers and Morris, 1983).

Fatty Acids

In most mammals, essential fatty acid requirements can be met by linoleic and/or linolenic acids. However, cats also require arachidonic acid (NRC, 1986). Other mammals convert linoleic to arachidonic acid to meet their requirement. The cat has low activity of enzymes critical to this conversion.

Vitamins

Cats cannot convert provitamin A compounds, such as beta-carotene, to retinol. Consequently, retinol, retinyl acetate or palmitate is required in the diet (NRC, 1986). Additionally, a dietary source of niacin is also required. Other mammals convert the amino acid tryptophan to niacin while in the cat this conversion does not occur (NRC, 1986). The whole prey diets consumed by free ranging cats are good sources of preformed vitamin A and niacin precluding problems in the wild.

WATER

As mentioned in previous sections, a clean source of water should be available at all times. Water bowls should be cleaned and sanitized daily.

CAPTIVE DIET FOR ADULTS

Diet Ingredients

Since the formulation of raw meat mixes, metabolic bone disease, resulting from slab meat diets has disappeared. Over time many of these diets have evolved with regard to nutrient levels, ingredients, and quality control, such that problems including inappropriately high levels of vitamin A, inconsistent or inappropriate ingredients, and high levels of bacterial load or unacceptable organisms including *Salmonella* and *Listeria* are less commonplace. Appropriate diets include meat mixes, bones, whole prey or carcass, and some slab meat. All, or selected items from this list, can be fed in combination if the overall nutrient content meets minimum nutrient concentrations (Tables 1 and 3).

Currently, several horsemeat mix diets are available. For example, those products manufactured by Dallas Crown[®], Nebraska[®], and Milliken Meats[®]. Additionally, Natural Balance[®] manufactures a beef based diets for large cats. These diets can contain meat products, solka floc, cereal grains, vitamin and mineral premixes. Correctly formulated meat mixes with appropriate ingredients, fed in combination with bones and/or whole prey can meet the nutritional needs as well as oral health of adult, pregnant, lactating, and growing jaguars (Table 4). Bones or whole prey should be included in the diet for abrading qualities in order to reduce plaque formation. A significant reduction in plaque and calculus can be achieved offering bones twice a week (Haberstroh et. al., 1984). Specifications for a raw meat diet are provided in Appendix A (Allen et. al., 1999) along with a questionnaire (Appendix B) to assess products and quality control of potential manufacturers.

Often slab or chunk meat is offered as a part of the diet as a vector for medications or for variety. These items can be fed as long as they have been included in the diet analysis that meets minimum requirements. If a cat must temporarily be fed a slab meat diet, recommendations for supplementation per 2 kilograms of horsemeat are 15 g of bone meal and 1 Centrum vitamin/mineral tablet (Ullrey and Bernard, 1989). Muscle meats are poor sources of calcium, vitamin A, D, and E, folacin, manganese and copper (Table 1). These products fed at the recommended levels, meet the minimum requirement range for growing cats. Supplementation above these levels, as well as supplementation for the meat mixes, is not warranted and may result in imbalances or toxicities.

How Much to Feed?

The appropriate quantity of diet is determined by the cat's body weight, activity level, physiological state, and energy content of the diet. Obesity can result from overfeeding and has been noted to be a problem in captivity. The equations generated by Kleiber and McNab can form a base from which to work. Example calculations are provided in Appendix C. The amount of food offered and estimated calories in Table 5 are reflective of good body condition for jaguars at the Fort Worth Zoo. Because different institutions may have larger or smaller exhibits, more or less active cats, feed a different diet, these values may not result in ideal body condition at other institutions. When possible, animals should be weighed to assess body condition and needs for diet changes. Depending on the structure of the animal, even at a

general ideal body weight for the species, it could be over or under weight. Consequently, it is important to visually assess each animal. A body condition chart is provided in Appendix C. This is a chart commonly used for the domestic cat. A jaguar specific chart is in development.

Depending on housing and climate, it may be appropriate to adjust diets seasonally. While a fast day in captivity does not reflect the natural feeding habits of a free-ranging animal consuming a large meal followed by a several day fast, it can be used in captivity to control body weight. Often bones are offered on fast days. It is important to note, depending on the supplier, some bones may contain more meat than the daily ration. Feeding road kill is not recommended due to possible transfer of parasites, disease, as well as high microbial loads. The USDA highly discourages this practice (USDA, 1998A).

Quality Control

Standards for inspecting meat and whole prey items are available in the USDA Manual of Standard Operating Procedures for Handling Frozen/Thawed Meat and Prey Items Fed to Captive Exotic Animals (Crissey et. al., 2001). Highlights from this document are included below. The complete document is available through the website: www.nal.usda.gov/awic. In general, inspection begins with the raw ingredients by the manufacturer and ends with the keeper placing the diet in the enclosure. At all times the following guidelines should be followed. Meat and meat mix standards: bright red or cherry color, fresh odor, firm and elastic to the touch. Whole prey standards: shine or luster to the skin, no breaks in the skin, no bloating or protrusion of viscera, no dehydration, eyes translucent, may be slightly sunken, fresh odor, firm and elastic, does not stay indented when touched.

Unpublished data (Allen, 2002) indicate that nutrient levels in meat mixes fed to large cats can vary. Ideally, each shipment of meat should be analyzed for nutrient content. Minimally, meat products should be analyzed once per year. To calculate metabolizable energy content, and thus determine appropriate amounts to feed, each product should be assayed for protein, fat, fiber, ash, and moisture. Calcium, phosphorus, potassium, sodium, magnesium, iron, copper, zinc, and manganese are useful measures to assess diets as well as monitor product consistency.

Additionally, food items should be monitored for microbial load. Suggested parameters to measure are noted in the appendix under Specifications for Raw Meat Diets (Allen et. al., 1999).

Sanitation and food safety concerns mentioned above are an important contributor to maintaining quality control. All areas where food is received, stored, and processed should follow Hazard Analysis and Critical Control Points (HACCP) principles (USDA, 1998B).

FOOD HANDLING, PREPARATION AND PRESENTATION

Considering the perishable nature of meat and prey items, it is critical follow food-handling procedures that aim to maintain the nutrient value of foods as well as avoid unhealthy microbial build up. The USDA Manual of Standard Operating Procedures for Handling Frozen/Thawed Meat and Prey Items Fed to Captive Exotic Animals (Crissey et. al., 2001) is a resource that should be on hand in every area where these foods are handled. The below guidelines do not include all the information available in this resource.

Storage

Refrigeration should be used for short-term storage only. The appropriate range for refrigeration is 4° to 6°C (40° to 43°F). Products not to be fed in 24 hours should be stored in a freezer. Once an item has been thawed, it should be fed within 24 hours. Appropriate freezer temperatures are -30° to -18°C (-22° to 0°F) or lower. Meat that must be stored for periods as long as 1 year should be held at the low end of the temperature range.

Thawing

Meat should never be thawed at room temperature. The preferred method of maintaining a wholesome product with the least microbial growth is to thaw it under refrigeration at 4° to 7°C (40° to 45°F). Boxes of bones should be broken up to facilitate timely thawing of all pieces. Large chunks of frozen meat can be sawed into smaller pieces. During the thawing process, meat, bones and prey items should be kept wrapped or in a container that will allow uniform thawing. Thawing in standing water is not recommended due to resulting nutrient loss. Meat and bones can be sealed in bags and thawed under running water at a temperature of 21°C (70°F) or below.

Feeding

Meat and prey items should be fed cold but not frozen. Food items should be placed in enclosures at times most likely to be consumed by the animal. A recommended guideline is 3 hours in an enclosure. Food pans or areas such as floors where food is offered, should be cleaned and sanitized daily.

Cleaning and sanitation

All equipment, receptacles or areas that maintain contact with raw meat items should be cleaned and sanitized daily. To accomplish sanitation, gross filth must be removed from all surfaces with a detergent. Once cleaned, the following methods can be used to sanitize. 1.) Contact with a solution of 100 ppm available chlorine solution for 20 seconds or 50 ppm for at least a minute. 2.) contact with a solution of 25 ppm available iodine for 1 minute. 3.) Contact with 200 ppm quaternary ammonium for 1 minute. 4.) Use of a dishwashing machine with approved sanitizing methods (chemical or hot water). 5.) Applying a safe and effective disinfectant after cleaning.

FOOD ENRICHMENT

All food items ingested should be considered a part of the diet. As such, the overall diet should meet the minimum nutrient requirements. A list of items offered jaguars is provided in the Enrichment chapter of this document.

HAND-REARING

Ann M. Ward, M.S., and Amy Hunt, M.S., Fort Worth Zoo

The below recommendations include available information on hand-reared jaguars (Oklahoma City Zoo and Caldwell Zoo) and the authors experience hand rearing several cat species (cheetah, tigers, clouded leopards and snow leopards). Other institutions have hand-reared jaguars, however protocols were not available for review. Below is summary information. For more complete information on hand rearing diets see the AZA Infant Diet Notebook (Meehan, 1994). For an extensive review of milk composition see Oftedal, 1984.

Milk Composition

Data were not found on the composition of jaguar milk. Limited information is available on the composition of milk of other cat species. It is important to remember that mother's milk will vary depending on stage of lactation (Oftedal, 1984). The nutrient content of milk of the domestic cat, cheetah, lion, lynx, and puma is compared to some milk replacers in Table 6. It is not clear what stage of lactation or which sampling technique was used in these data on various cat species. Consequently, these values may not be representative of what the cub is actually consuming. However, these values may provide a range from which to work.

Formula Selection

Though four products are listed as examples, KMR[®] is the formula used by all zoos that supplied jaguar hand rearing information. The authors have raised several species using Esbilac[®] and Milk Matrix[®] 33/40. The choice to use Esbilac[®] and Milk Matrix[®] 33/40 was based on their carbohydrate content more similar to the range for exotic species. In general the Milk Matrix[®] line of products in this table are similar in overall nutrient content to KMR[®] and Esbilac[®]. However, differences in ingredients do exist. KMR[®] and Esbilac[®] contain animal sources of fat while the Milk Matrix[®] products in Table 6 contain vegetable sources of fat. Any of these products could be used to raise jaguars. A product such as, Lactaid[®] can be added to formulas to assist with carbohydrate digestion.

Amount to Feed

Cubs should be weighed daily or at least twice a week. Cubs should be weighed at the same time each time they are weighed to allow accurate comparison of weight over time. Weighing before or after a feed can significantly affect the weight. Amount to feed should be based on body weight. When the amount fed was adjusted frequently, cubs had more consistent growth (Figure 1). A general amount guide for cats is 20 % of body weight per 24-hour period. Hand reared jaguars were fed, initially 17 – 23% of body weight up to day 32. These cubs obtained growth rates close to those of parent-reared animals (Figure 1).

It appears carnivore maximum stomach capacity may be 5-7% of body weight. Consequently, to feed 20% of body weight, a minimum of 5 feeds should be offered. One zoo started with 7 feeds per 24 hour period. The amount to feed daily should be determined using the first weight and the above percentages. Possible gastrointestinal tract stress can be avoided if the cub is not allowed to consume large volumes or inconsistent amounts. Animals should not be fed as much as they will take; this often leads to overfeeding and diarrhea.

Records

A detailed nursery log should be kept recording date, times fed, amount fed, body weight, urination/defecation, stool condition, remarks/notes. A sample nursery log is in the appendix. Keeping a log will help to assess progress. This information can be used to determine if changes are needed/foresee any potential problems.

Feeding Apparatus

In general, felids of the genus *Panthera* nurse well from human nursing bottles. Preemie nipples or cross cut normal nipples can be used. When setting out to hand rear a wide selection of nipple types and openings should be available. Trial and error with each cub and changes from one nipple to another are usually necessary.

Sanitation

Bottles and bowls should be cleaned and sanitized between feedings. After cleaning, bottles can be boiled to avoid contamination from the environment. Formula left over at the end of a 24-hour period should be discarded.

Weaning

Solids can be introduced at five to six weeks in the form of a nutritionally complete canned cat food or a blenderized nutritionally complete raw meat diet. By this time the cubs should be consuming formula from a bowl. The blended canned or raw meat diet can be added to the formula in the bowl. If canned cat food is used, it will need to be mixed with the raw meat diet and gradually decreased and removed over time. The benefit to using a canned diet initially is to delay microbial introduction to the cub's gastrointestinal tract. However, several species have been weaned onto raw diets without apparent ill effects. At this time the formula amount can begin to decrease as a percent of body weight. Complete removal of formula occurred as early as 7.2 weeks and as late as 11 weeks.

10. TABLES

Table 1: Nutrient content of prey items and muscle meat on a dry matter basis.

	Units	Whole	Whole	Whole	Whole	Guinea	Skeletal muscle		
		Chicken ¹	Rabbit ¹	Rat ¹	Deer ¹	Pig ¹	Horses ²	Cattle ²	Deer ²
Moisture	%	32.5	26.2	33.9	41.1	31.3	27	28	30
Protein	%	42.3	65.2	61.8	47.4	51.4	76	63	65
Fat	%	37.8	15.8	32.6	41.4	46.1	18	29	29
Fiber	%	ND	N	ND	ND	ND	ND		
Ash	%	9.4	3.4	9.8	11.4	9.2	4	3	3.4
Vitamin A	IU/kg	35600	6200	151389	ND	16506	2593	1428	
Vitamin D3	IU/kg	51.3	ND	139.2	ND	24.2	0	0	
Vitamin E	IU/kg	ND	ND	ND	ND	ND	ND	3	
Calcium	%	2.22	5.93	2.62	3.09	3.02	0.05	0.03	0.03

Phosphorous	%	1.4	3.43	1.48	2.26	ND	0.34	0.55	0.59
Potassium	%	ND	0.72	ND	0.95	ND	1.1	1.01	1.07
Sodium	%	ND	0.26	ND	0.39	ND	0.19	0.17	0.3
Magnesium	%	0.5	0.18	0.08	0.19	0.07	0.05	0.06	0.06
Iron	ppm	122.2	100	148	164.5	56.4	232	78	165
Copper	ppm	3.6	4.6	6.3	26.1	5.6	3	2	5
Zinc	ppm	116.1	84	62.1	68.4	46.4	128	106	68
Manganese	ppm	10.1	2.4	11	28.5	6.6	0.6	0.3	0.7
Selenium	ppm						0.8	0.3	0.4

¹Dierenfeld, *et al.*, 2002

²Ullrey & Bernard, 1989ND – not determined

Table 2: Recommended minimum nutrient concentrations for diets fed to jaguars.¹

Nutrient	<i>Units</i>	Growth	Maintenance
Protein	%	30	26
Fat	%	9	9
Taurine	%	0.1	0.1
Vitamin A	IU/g	9	5
Vitamin D3	IU/g	0.75	0.5
Vitamin E	IU/g	100	100
Thiamin	ppm	0.1	0.1
Riboflavin	ppm	5	5
Pyridoxine	ppm	4	4
Niacin	ppm	60	60
Pantothenic acid	ppm	5	5
Folic acid	ppm	0.8	0.8
Biotin	ppm	0.07	0.07
Vitamin B ₁₂	ppm	0.02	0.02
Choline	ppm	2400	2400
Calcium	%	1.0	0.6
Phosphorus	%	0.8	0.5
Potassium	%	0.6	0.6
Sodium	%	0.2	0.2
Magnesium	%	0.08	0.04
Iron	ppm	80	80
Copper	ppm	5	5
Iodine	ppm	0.35	0.35
Zinc	ppm	75	75
Manganese	ppm	7.5	7.5
Selenium	ppm	0.1	0.1

¹Minimums meet AAFCO minimum profiles for practical diets (1994) and exceeds the NRC (1986) minimum requirements for growth on purified diets.

Table 3: Nutrient content of commercially available meat mixes on a dry matter basis.

Nutrient	units	Dallas Crown ¹		Nebraska Feline ²	Nebraska Canine ²	Milliken Meats ¹
		95/5	85/15			
Moisture	%	69.7	62.2	58.4	67.6	30.6
Protein	%	61.5	52.9	55.7	58	64.4
Fat	%	16.3	32.1	41	27.7	28.6
Fiber	%	4.3	3.5	ND	ND	ND
Ash	%	8.16	6.27	8.9	7.4	ND
Vitamin A	IU/kg	12300	ND	17.3	9.7	ND
Vitamin D	IU/kg	N	ND	ND	ND	ND
Vitamin E	IU/kg	473	ND	54.1	52.4	ND
Calcium	%	1.56	1.25	1.3	1.9	0.54
Phosphorous	%	1.36	1.01	1.2	1.3	0.51
Potassium	%	1.2	0.84	ND	ND	0.8
Sodium	%	0.59	0.49	0.4	0.4	0.182
Magnesium	%	0.08	0.06	0.08	0.08	0.09
Iron	ppm	117	95	633	645	117
Copper	ppm	24	17	7	10	3
Zinc	ppm	127	96	132	128	143
Manganese	ppm	10.5	7.2	27	23	17

¹Fort Worth Zoo, unpublished data

²Dierenfeld, 19__

ND – not determined

Table 4: Selected nutrient composition (dry matter basis) of mean daily diet offered growing and adult jaguar at the Fort Worth Zoo and recommended minimum nutrient concentrations for jaguars.¹

Nutrient	Units	Fort Worth Zoo Diet	Minimum/Adult	Minimum/Growth
Protein	%	50.8	26	30
Fat	%	23.9	9	9
Vitamin A	IU/g	12.2	5	9
Vitamin E	IU/g	315	100	100
Calcium	%	1.3	0.6	1.0
Phosphorus	%	1.2	0.5	0.8
Potassium	%	1.0	0.6	0.6

Sodium	%	0.6	0.2	0.2
Magnesium	%	0.07	0.04	0.08
Iron	ppm	161	80	80
Copper	ppm	24.2	5	5
Zinc	ppm	77.0	75	75
Manganese	ppm	9.4	7.5	7.5

¹Minimums meet AAFCO minimum profiles for practical diets (1994) and exceeds the NRC (1986) minimum requirements for growth on purified diets.

Table 5: Age, body weight (BW), as fed intake (AFI) in grams per day and as a % of body weight, and calculated metabolizable energy intake (CMEI) of 2.2 jaguars housed at the Fort Worth Zoo.

Animal ID	Age, years	BW, kilograms	AFI, g/day	AFI, %BW	CMEI, kcal/d
200993	0.6	16.3	257	1.6	308
200993	0.7	17.7	283	1.6	340
200993	0.8	18.8	326	1.7	391
200993	0.9	20.1	375	1.9	450
200993	1.0	21.1	413	2.0	503
200994	0.6	20.5	257	1.3	308
200994	0.7	22.8	283	1.2	340
200994	0.8	24.9	326	1.3	391
200994	0.9	23.7	375	1.6	450
200994	1.0	25.1	375	1.5	450
200360	3.3-5.4	50.4-57.4	2117	3.7-4.2	2548
200360	5.5-5.8	52.5-55.9	2430	4.4-4.6	2924
200699	5.5-6.7	59.2-61.2	2192	3.6-3.7	2638
200699	7.3	53.8	2409	4.5	2899

Table 6: The nutrient content of milk of several cat species compared to available milk replacers on a dry matter basis.

Species ¹	Protein, %	Fat, %	Carbohydrate, %	Dry Matter, %
Cheetah (<i>Acinonyx jubatus</i>)	39.7	40.1	14.8	23.7
Lion (<i>Panthera leo</i>)	30.8	57.9	11.2	30.2
Leopard (<i>Panthera pardus</i>)	49.1	28.8	18.6	22.6
Puma (<i>Puma concolor</i>)	33.8	52.4	11.0	35.5
Lynx (<i>Lynx lynx</i>)	47.0	28.6	20.7	21.7
Range	30.8-49.1	28.6-57.9	11.0-20.7	21.7-35.5
Domestic cat (<i>Felis catus</i>)	42.2	25.0	26.1	18.2
Product	Protein, %	Fat, %	Carbohydrate, %	Dry Matter, %

KMR [®]	42.2	25	26.1	18.2
Milk Matrix [®] 42/25	43.4	29.0	18.6	32.5
Esbilac [®]	33.2	43.0	15.8	15.2
Milk Matrix [®] 33/40	34.0	42.9	15.6	32.7

¹Jenness and Sloan, 1970.

FIGURES

Figure 1: Growth of hand-reared (HR) and parent-reared (PR) jaguar cubs

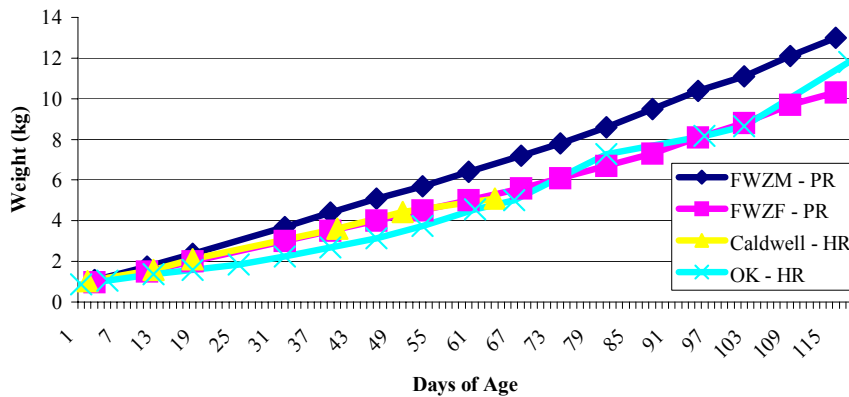

12. APPENDICES

Appendix A: Specifications for a raw meat diet (Allen et. al., 1999)

Ingredients: Horsemeat or horsemeat trimmings, solka floc (wood cellulose), calcium phosphate tribasic, sodium chloride, carnivore trace element premix, carnivore vitamin premix, choline chloride, taurine, stabilized L-ascorbyl-2-polyphosphate.

Ingredient and Product Standards: All meat and meat products shall originate from animals slaughtered in plants subject to the Meat and Poultry Inspection Operations regulations of the USDA Food Safety and Inspection Service (FSIS), or under a system of inspection approved by FSIS. All bones, cartilage, heavy connective tissue, lymph glands, and central nervous system tissue shall be removed. Likewise, meat and meat products that originate from animals or carcasses designated as 3-D or 4-D shall not be used. Other (non-meat) ingredients shall conform to standards as defined by the Association of American Feed Control Officials

(AAFCO). The product shall be routinely monitored for specific microbial populations. The diet must test negative for the presence of *Salmonella* and *Listeria*, and within specified tolerance limits for total coliforms and *E. coli*.

Nutrient Concentrations: The product has been formulated to meet or exceed the minimum NRC nutrient concentrations required in purified diets for the growing domestic kitten and AAFCO nutrient profiles for growth and reproduction of cats fed practical diets. All values, except moisture, are expressed on a dry matter basis.

Moisture, % (maximum)	70	Crude Protein, % (minimum)	30
Crude Fat, % (minimum)	10	Crude Fiber, % (maximum)	3
Lysine, %	4.3	Taurine, %	0.3
Calcium, %	1.3	Phosphorus, %	1.2
Magnesium, %	0.09	Zinc, ppm	110
Vitamin A, IU/kg	14,000	Vitamin E, IU/kg	470

Microbial guidelines for raw meat-based diets:

Test	Acceptable (m)
Standard plate count	<500,000
Total coliforms/g	<500
<i>E. coli</i> /g	<100
Staph species (TSN+)/g	<100
<u><i>Salmonella</i>/25/g</u>	negative

Appendix B: Questionnaire for potential suppliers

1. Please describe your HACCP program:
2. Are your records available for review?
3. What kind of training do you provide to your employees?
4. Is staff certified for sanitation/food handling? If so, by what agency?
5. Is there a regulatory body that inspects your operation? If so, how often?
6. Please describe your quality assurance program:
7. What is the inspection procedure (evaluation criteria) for raw ingredients entering the plant?
8. What is the inspection procedure (evaluation criteria) for finished product?
9. How do you trace ingredients (link) to the finished product?
10. Please describe your product recover program?
11. How do you handle customer complaints?
12. What is your schedule for preventive maintenance?
13. What analysis do you conduct in house (lab)?
14. For your lab, what quality control practices do you have in place?
15. What analyses do you conduct in labs outside of the plant and how often?
16. How often is the water source checked?
17. Please describe your pest control program:
18. What is your freezing method?
19. What temperature is the product kept at through processing?
20. Do you utilize lot numbers, batch numbers, etc and is this on your label?

Appendix C: Equations useful for calculating energy needs and consequently, appropriate amounts of a diet

Basal Metabolic Rate (BMR) =
 $70 \times \text{body weight in kilograms}^{.75}$ (Kleiber)
 $91.8 \times \text{body weight in kilograms}^{.813}$ (McNab)

Estimated energy for maintenance may be 2 times BMR.

Energy Content or Metabolizable Energy (ME)
 $\text{ME (kcal/kg)} = 10(3.5 \times \text{crude protein}) + (8.5 \times \text{crude fat}) + (3.5 \times \text{carbohydrate or nitrogen free extract/NFE})$

$$\text{NFE} = 100 - (\text{crude protein \%} + \text{crude fat\%} + \text{crude fiber\%} + \text{moisture\%} + \text{ash\%})$$

Example:

Adult jaguar 53.9 kilograms

Nutrient analysis of meat mix offered on an as fed basis:

16 % protein
 6.1 % fat
 1.1 % fiber
 1.2 % ash
 62.2 % moisture

1.) Calculate estimated BMR energy needs:

$$70 \times \text{body weight in kilograms}^{.75} \text{ (Kleiber)}$$

$$70 \times 53.9^{.75} = 1392 \text{ kcal}$$

$$91.8 \times \text{body weight in kilograms}^{.813} \text{ (McNab)}$$

$$91.8 \times 53.9^{.813} = 2348 \text{ kcal}$$

Range 1392 – 2348 kcal/day

2.) Calculate estimated maintenance energy needs:

$$\text{BMR} \times 2$$

$$(1392 - 2348) \times 2$$

Range 2784 – 4696 kcal/day

3.) Calculate metabolizable energy content of the diet:

$$\text{NFE} = 100 - (\text{crude protein \%} + \text{crude fat\%} + \text{crude fiber\%} + \text{moisture\%} + \text{ash\%})$$

$$\text{NFE} = 100 - (16 + 6.1 + 1.1 + 62.2 + 1.2)$$

$$\text{NFE} = 13.4$$

ME (kcal/kg) = $10((3.5 \times \text{crude protein}) + (8.5 \times \text{crude fat}) + (3.5 \times \text{carbohydrate or nitrogen free extract/NFE}))$

ME (kcal/kg) = $10((3.5 \times 16) + (8.5 \times 6.1) + (3.5 \times 13.4))$

ME = 1548 kcal/kg



4.) Calculate kilograms of diet needed to meet estimated maintenance range:

$2784 \text{ kcal/day} / 1548 \text{ kcal/kg} = 1.8 \text{ kilograms}$

$4696 \text{ kcal/day} / 1548 \text{ kcal/kg} = 3.0 \text{ kilograms}$

Range 1.8 – 3.0 kilograms of diet

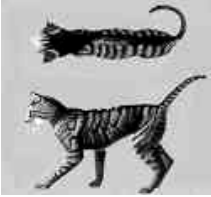
Appendix D: Body condition scoring chart

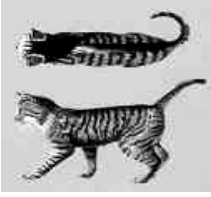
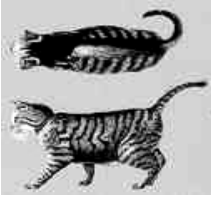
<p>1. Emaciated - Ribs obvious on short-haired cats. Pelvic bones and other bony structures easily palpated. Accentuated concave abdominal tuck. Accentuated, severe hourglass shape to waist. No discernable body fat. Obvious loss of muscle mass.</p>	
<p>2. Thin - Ribs easily palpable with little fat cover. Lumbar (back) vertebrae obvious. Minimal abdominal fat. Marked hourglass shape to waist.</p>	
<p>3. Optimal - Ribs, lumbar vertebrae, pelvic bones and other bony structures easily palpable with slight fat cover. Concave abdominal tuck. Smooth hourglass shape to waist. Abdominal fat pad minimal.</p>	
<p>4. Fat - Ribs are difficult to palpate. Pelvic bones are palpable with moderate tissue cover. Tail base has fat deposition with moderate soft tissue cover. Concave tuck is decreased to absent. Loss of hourglass shape to waist with back slightly broadened. Moderate abdominal fat pad.</p>	

5. Obese - Ribs are very difficult to impossible to palpate. Heavy fat deposits on back, face and limbs. Abdomen is distended with extensive abdominal fat deposits. Back is markedly broadened.

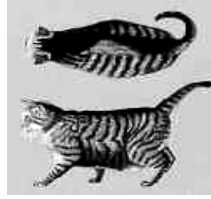

Images courtesy of Ralston Purina Company

Appendix E: Daily feeding schedule for adult jaguars (1.1) housed at the Fort Worth Zoo March 2003.

Food Item	Amount in grams or each	Weekly Schedule						
		Sun	Mon	Tue	Wed	Thur	Fri	Sat
Dallas Crown 95/5	2824-2843	X		X	X		X	X
Dallas Crown 95/5	2561-2663		X					
180 g rat	1 rat		X					
Shank bone	½ bone					X		

Appendix F: Body weights (BW) of captive jaguars (Panthera onca), ISIS 1999 and Fort Worth Zoo 2003.

Age, years	BW, kilograms	Standard Deviation	Number of Animals
Birth	1.0	0.1	2
0.25	9.3	1.6	2
0.5	17.8	3.3	2
0.75	21.1	3.7	2
1	23.2	2.8	2
1.8-2.2	53.5	13.9	9
3.3-7.3	54.7	3.2	2
9.5-10.5	65.8	11.1	17
19-21	56.4	13.4	7

- Allen, M.E., O.T. Oftedal, K.E. Earle, J. Seidensticker and L. Vilarin. 1995. Do maintenance energy requirements of felids reflect their feeding strategies? Proceedings of the First Annual Conference of the Nutrition Advisory Group. Toronto, Ontario, Canada. Pp. 97-103.
- Barbiers, R.B., L.M. Vosburgh, P.K. Ku, and D.E. Ullrey. 1982. Digestive efficiencies and maintenance energy requirements of captive wild felidae: cougar (*Felis concolor*); leopard (*Panthera pardus*); lion (*Panthera leo*); and tiger (*Panthera tigris*). *J. Zoo An. Med.* 13:32-37.
- Crissey, S.D., K.A. Slifka, P. Shumway, and S.B. Spencer. 2001. Handling frozen/thawed meat and prey items fed to captive exotic animals, a manual of standard operating procedures. USDA Animal and Plant Inspection Service. National Agricultural Library,
- Dierenfeld, E.S., H.L. Alcorn, and K.L. Jacobsen. 2002. Nutrient Composition of Whole Vertebrate Prey (Excluding Fish) Fed in Zoos. United States Department of Agriculture. Web site: www.nal.usda.gov/awic/zoo/WholePreyFinal02May29.pdf
- Hackenburger, M.K. and J.L. Atkinson. 1983. The apparent diet digestibilities of captive tigers. Proceedings of the Third Annual Dr. Scholl Conference on the Nutrition of Captive Wild Animals. Lincoln Park Zoological Gardens, Chicago, IL. Pp. 70-83.
- Jenness, R., and R.E. Sloan. 1970. The composition of milks of various species: A review. *Dairy Sci. Abstr.* 32:599-612.
- Kendall, P.T., S.E. Blaza, and P.M. Smith. 1983. Comparative digestible energy requirements of adult beagles and domestic cats for body weight maintenance. *J. Nutr.* 113: 1946-1955.
- Lindburg, D.G. 1988. Improving the Feeding of Captive Felines Through Application of Field Data. *Zoo Biology* 7: 211-218
- McNab, B.K. 1989. Basal Rate of Metabolism, Body Size, and Food Habits in the Order Carnivora. In *Carnivore Behavior, Ecology, and Evolution*. Vol. 1. Gittleman, J., Ed. Pp. 335-354.
- Meehan, T.P. 1994. Hand rearing felids. In: *American Zoo and Aquarium Association Infant Diet Notebook*.
- Morris, L.G., J. Fujimoto, and S.C. Berry. 1974. The comparative digestibility of a zoo diet fed to 13 species of felid and a badger. *Int. Zoo Yearb.* 14:169-171.
- Morris, J.G., and R.Q. Rogers. 1983. Nutritionally related metabolic adaptations of carnivores and ruminants. In *Plant, animal, and microbial adaptations to terrestrial environments*, ed. N.D. Margaris, M. Arianoutsou-Faraggitaki, and R.J. Reiter. Plenum Publishing. New York, NY. Pp. 165-180.

National Research Council. 1986. Nutrient Requirements of Domestic Animals, 3rd ed. Nutrient Requirements of Cats. National Academy of Sciences – National Research Council, Washington, D.C.

Oftedal, O.T. 1984. Milk composition, milk yield and energy output at peak lactation: A comparative review. Symp. Zool. Soc. London 51:33-85.

Robbins, C.T. 1993. Wildlife Feeding and Nutrition. Academic Press, Inc. New York, NY. Pp. 125.

Stevens, C.E. and I.D. Hume. 1995. Comparative physiology of the vertebrate digestive system; second edition. Cambridge University Press. 40 West 20th Street, New York, NY 10011-4211. Pp. 58.

Ullrey, D.E. and J.B. Bernard. 1989. Meat diets for performing exotic cats. Journal of Zoo and Wildlife Medicine 20(1): 20-25.

United States Department of Agriculture. 1998A. Policy #25 – Proper diets for large felids. Animal and Plant Health Inspection Service, Washington, D.C. Web site: www.aphis.usda.gov/ac/Policy25.html.

United States Department of Agriculture. 1998B. The seven HACCP principles. Food and Safety Inspection Service, Washington, D.C. Web site: www.fsis.usda.gov/OA/background/keyhaccp.htm.

Wynne, J.E. 1989. Comparative digestibility values in four species of felidae. Journal of Zoo and Wildlife Medicine 20(1):53-56.

Health Care

Sharon L. Deem, DVM, National Zoological Park

INTRODUCTION

In many ways, when providing veterinary care for jaguars, they can be viewed as “big domestic cats,” a species for which there is a great deal of veterinary knowledge. However, one must also appreciate that these animals are strong (They have the strongest jaw in relation to head size of any of the cats.) and require chemical immobilization for most veterinary procedures. Although a literature review of diseases documented in jaguars is provided below, the clinician should be aware of the possibility that a jaguar may present with other diseases, not yet reported.

PRESHIPMENT, SHIPMENT, AND QUARANTINE REQUIREMENTS

Preshipment

Medical history should be received and reviewed by the receiving institution’s veterinary staff prior to shipment. Preshipment examination should include a complete physical examination, complete blood count (CBC), chemistry profile, fecal parasite examination, enteric pathogen screen, serology for calicivirus, canine distemper virus, *Dirofilaria immitis*, feline immunodeficiency virus, feline infectious peritonitis, feline leukemia virus, feline panleukopenia, herpesvirus, *Leptospira interrogans* spp., *Toxoplasma gondii*, thyroid screening, and thoracic and abdominal radiographs. If not already properly identified, the jaguar should also be permanently identified with a transponder chip. The animal must be current on all recommended vaccinations (see below), which minimally should include rabies and Fel-O-Vax[®] (panleukopenia, rhinotracheitis, and calicivirus).

Shipment

Prior to shipment, the jaguar must be healthy as determined by the sending institution’s veterinarian. There are crate specifications that must be met to safely transport a jaguar. These specifications are addressed in the captive management chapter of this manual. Additionally, there are USDA requirements from the live animal regulations and International Air Transport Association rules for shipment via commercial airline. If the animal is to be shipped on land, the same high standards should be followed to ensure the animal’s safety. Refer to the Transport section of these guidelines for further details.

Quarantine

The quarantine period should last for a minimum of 30 days and a maximum of 45 days. This range is suggested in order to accomplish quarantine goals while minimizing stress in housing that is usually not long-term appropriate. During the quarantine period, three fecal samples for

internal parasite evaluation should be submitted and all parasites treated appropriately while in quarantine. After 14 – 21 days in quarantine, the jaguar should receive a quarantine examination that includes those tests listed for the pre-shipment examination. The quarantine examination also provides a good opportunity to satisfy all those requirements not met (if any) during the pre-shipment examination.

Food provided at the sending institution may be different from that which will be fed at the receiving institution and diets from the sending zoos should accompany the animal or at least be used initially by the receiving institution. It is imperative that the jaguar's diet not be switched immediately upon arrival at the new institution. It is better to slowly transition the jaguar to the new diet while weaning it off the old diet. This will minimize possible anorexia and gastrointestinal problems that may occur with any dietary change. Most zoos will begin to transition the diet during the quarantine period.

ANESTHESIA

Chemical immobilization is necessary when performing virtually any veterinary procedure on a jaguar. Jaguars should be fasted for at least 24 hours and water should be withheld for at least 12 hours prior to anesthesia. Similar to other felids, anesthesia of jaguars is usually uneventful if proper drugs and techniques are used. However, the clinician must always be prepared for handling emergency situations (Kreegar, 1996) as these can and do arise.

There are a number of anesthetic protocols that have been successfully used for free-ranging and captive jaguars. A review of these protocols can be found in Deem and Karesh, 2001 and Deem, 2002. Following are three protocols that have provided good results for captive jaguars.

Telazol (4-6 mg/kg) i.m.

Supplemental anesthesia should be ketamine at a dose of 1 – 1.5 mg/kg i.v. or 1 – 2 mg/kg i.m., as needed to maintain an adequate level of anesthesia.

Unlike tigers (Armstrong, 1990), there are no reports of adverse reactions to Telazol® in jaguars. Reactions should be reported to the SSP veterinary advisor if they do occur.

Ketamine (4 mg/kg) and Xylazine (2 mg/kg) i.m.

Supplemental anesthesia should be ketamine at a dose of 1 – 1.5 mg/kg i.v. or 1 – 2 mg/kg i.m., as needed to maintain an adequate level of anesthesia. Yohimbine (0.125 mg/kg) should be delivered following anesthesia to reverse xylazine.

Ketamine (2.5- 4 mg/kg) and Medetomidine (50-70 mcg/kg) i.m.

Supplemental anesthesia should be ketamine at a dose of 1 – 1.5 mg/kg i.v. or 1 – 2 mg/kg i.m., as needed to maintain an adequate level of anesthesia. Atipamezole (5 X medetomidine dose) i.m. should be delivered following anesthesia to reverse the medetomidine.

For any of these three protocols, atropine (0.04 mg/kg) or glycopyrrolate (0.01 – 0.02 mg/kg) can be administered as a single dose either subcutaneously or intramuscularly if the cat has excessive salivation.

Anesthesia is best maintained in captivity by providing isoflurane via endotracheal tube. Maintenance levels usually are 1 – 2% but may need to be adjusted based on careful monitoring of the plain of anesthesia.

PREVENTIVE MEDICINE

In addition to veterinary care, the health of captive jaguars is dependent on environmental enrichment, good hygienic practices, proper nutrition, and pest control. These factors are addressed elsewhere in this manual.

Medical Record Keeping

Medical record keeping is a necessary component of any health program, for the individual animal and the captive and free-ranging populations of the species.

MedARKS' software program (ISIS, 12101 Johnny Cake Rd., Apple Valley, MN 55124 USA) is currently the most commonly used program in AZA institutions. It is imperative that all veterinary procedures and health-related findings are carefully recorded for every jaguar in captivity.

Table 1: Physiological reference ranges for captive jaguars (*Panthera onca*) submitted to the International Species Information System from 39 member institutions (ISIS, 1999)

Parameter	Mean	Standard deviation	Sample size *	Animals **
WBC ($10^3/\mu\text{l}$)	12.01	4.099	191	98
RBC ($10^3/\mu\text{l}$)	7.26	1.36	161	84
Hemoglobin (g/dl)	11.8	2.3	166	86
Hematocrit (%)	34.8	5.7	199	102
MCV (fl)	48.8	9.3	159	82
MCH (pg/cell)	16.6	3.9	154	79
MCHC (g/dl)	33.7	3.3	165	86
Platelet count ($10^3/\mu\text{l}$)	273	107	37	30
NRBC/100 WBC	1	1	11	11
Reticulocytes (%)	0.0	0.0	5	5
Segmented neutrophils ($10^3/\mu\text{l}$)	8.56	3.92	179	90
Lymphocytes ($10^3/\mu\text{l}$)	2.15	2.09	182	94
Monocytes ($10^3/\mu\text{l}$)	0.35	0.39	142	84

Eosinophils (10 ³ /μl)	0.297	0.307	135	77
Basophils (10 ³ /μl)	0.051	0.1	41	26
Neutrophilic bands (10 ³ /μl)	0.813	1.657	77	46
Calcium (mg/dl)	9.8	0.8	148	80
Phosphorus (mg/dl)	5.0	1.1	131	74
Sodium (mEq/L)	151	4	132	75
Potassium (mEq/L)	4.0	0.4	132	75
Chloride (mEq/L)	121	5	123	70
Bicarbonate (mEq/L)	170.0	316.7	4	3
CO ₂ (mEq/L)	16.0	2.9	60	36
Osmolarity (mOsmol/L)	303	7	30	19
Iron (μg/dl)	84	20	15	7
Magnesium (mg/dl)	2.66	0.54	5	5
BUN (mg/dl)	24	9	155	88
Creatinine (mg/dl)	2.0	0.7	152	84
Uric Acid (mg/dl)	0.3	0.3	59	34
Total bilirubin (mg/dl)	0.2	0.1	133	78
Direct bilirubin (mg/dl)	0.0	0.1	45	26
Indirect bilirubin (mg/dl)	0.1	0.1	45	26
Glucose (mg/dl)	137	55	154	86
Cholesterol (mg/dl)	246	60	140	78
Triglyceride (mg/dl)	32	19	75	40
CPK ^{***} (IU/L)	317	279	62	44
LDH ^{***} (IU/L)	163	162	90	55
ALP ^{***} (IU/L)	33	33	147	80
AAT ^{***} (IU/L)	55	25	119	69
AST ^{***} (IU/L)	35	16	150	84
GGT ^{***} (IU/L)	3	3	56	33
Amylase (U/L)	1816	901	40	25
Lipase (U/L)	14	12	12	8
Total protein (g/dl)	7.3	0.6	142	78
Globulin (g/dl)	3.9	0.8	113	62
Albumin (g/dl)	3.4	0.4	114	62
Total triiodothyronine (ng/ml)	154.0	0.0	1	1
Total thyroxine (μg/dl)	2.5	2.0	8	7
Body temperature (⁰ F)	100.9	2.0	107	67
Weight: 1.8-2.2 years old (kg)	53.49	13.85	9	9
Weight: 9.5-10.5 years old (kg)	65.76	11.07	24	17
Weight: 19-21 years old (kg)	56.39	13.38	12	7

Sample size^{*} - Number of tests run per parameter.

Animals^{**} - Number of animals sampled per parameter.

*** CPK – Creatinine phosphokinase; LDH – Lactated dehydrogenase; ALP – Alkaline phosphatase; AAT – Alanine aminotransferase; AST- Aspartate aminotransferase; GGT – Gamma glutamyltransferase.

Physical Examinations (Quarantine and annual examinations)

Jaguars should be examined prior to shipment, while in quarantine and thereafter on an annual schedule. The physical examination should include body weight, temperature, pulse, respiration, careful nail and pad evaluation, dental examinations with particular attention to fractured canines, and whole body exam for abscesses and lacerations. Normal parameters include: body weight (males are 90 – 120 kilograms and females are 60 – 90 kilograms); temperature (37 – 39.5⁰ C or 98.6 – 103.1⁰ F); pulse (70 – 140 bpm); and respiration (8 – 24 bpm).

Dental Care

A thorough oral examination is an integral part of a physical examination. The teeth and soft tissue structures of the mouth and throat should be examined for abnormalities. Dental tartar and calculi are a common problem in captive jaguars. Tooth scaling and polishing should be a routine part of any physical examination. Additionally, fractured teeth (most commonly canines) can be a serious problem in jaguars. Teeth should be carefully examined for fractures and root canal performed when deemed appropriate. Dental films also provide additional diagnostic capabilities.

Laboratory Testing and other diagnostic modalities

Clinical pathology is an important component of the preshipment, quarantine and annual examinations. Laboratory tests that should be performed include: complete blood count (CBC), chemistry profile, fecal parasite examination, enteric pathogen screen, serology for calicivirus, canine distemper virus, *Dirofilaria immitis*, feline immunodeficiency virus, feline infectious peritonitis, feline leukemia virus, feline panleukopenia, herpesvirus, *Leptospira interrogans* spp., *Toxoplasma gondii*, and thyroid screening. Thoracic and abdominal radiographs should be taken annually with special attention to the musculoskeletal condition and internal organs. Ultrasonography may also provide information especially for heart, abdominal, and reproductive assessments. In male jaguars, semen evaluation is important as covered in the chapter on reproduction management.

The International Species Information System provides physiologic reference ranges for captive jaguars with division by sex and age (ISIS, 1999). Table 1 provides the physiological reference ranges for captive jaguars of all ages and sexes from 39 member institutions (ISIS, 1999).

Vaccinations

Vaccinations have been the mainstay of preventive medicine programs for both domestic and non-domestic cats. However, in recent years vaccine induced neoplasia (Morrison *et al.*, 2001) has become a concern in domestic cats and may be a concern in non-domestic felids. Additionally, there is species variation in immunologic response to vaccines, and thus vaccines may afford protection in one species but not another. The author knows of no experimental studies on the efficacy of vaccines in jaguars. Killed (or recombinant) vaccines should always be used in jaguars as modified live virus vaccines may cause vaccine-induced disease.

Vaccines should be used in conjunction with other preventive measures including: limiting contact that captive jaguars have with free roaming wildlife and feral carnivores (domestic cats and dogs), good hygienic standards, and maintaining adequate nutrition and overall health of jaguars to ensure strong immune systems. Vaccination for protection against panleukopenia, rhinotracheitis, calicivirus, and rabies viruses should be routinely given to jaguars housed at AZA institutions. A dose of 1 ml (standard domestic cat dose) should be used in jaguars of all ages. Currently the AZA Felid TAG does NOT recommend the routine use of canine distemper vaccine, feline leukemia or feline immunodeficiency virus vaccines.

1. **Vaccination Schedules**

Vaccination schedules for non-domestic species are based on recommendations for domestic animals. Domestic animals that received colostrum as neonates should be vaccinated every 3-4 weeks between 6 and 16 weeks of age. Colostrum-deprived neonates should be given two vaccinations administered on a 3-4 week interval starting at 2 weeks of age because maternal antibodies acquired *in utero* should be absent by 4-6 weeks of age.

Adults that have never been vaccinated previously should be vaccinated twice, 3-4 weeks apart. Yearly vaccine boosters may be advisable in non-domestic species for which data on antibody persistence post-vaccination are lacking. However, the risk versus benefit ratio between exposure to infectious agents and the possible development of vaccine-induced neoplasia should be taken in to consideration when developing long-term vaccination policies for captive jaguars.

2. **Vaccinations for Specific Infectious Agents**

There are many brands of vaccines as well as vaccines for additional infectious agents used in jaguars that are not listed in this manual. Clinicians should only use killed products and should be familiar with the vaccines they administer. Any adverse reactions should be reported to the SSP veterinary advisor so that this information can be disseminated to other institutes that house jaguars.

3. **Panleukopenia, Rhinotracheitis, and Calicivirus:**

Panleukopenia (feline distemper), rhinotracheitis, and calicivirus are the most common viral infectious diseases of domestic cats. All captive jaguars should be vaccinated against these three viral diseases using the killed vaccine (Fel-O-Vax®, Fort Dodge Lab Inc., Fort Dodge, IA 50501).

4. **Rabies:**

Rabies is a highly fatal member of the rhabdovirus family requiring direct contact for transmission. All warm blooded animals are susceptible to clinical rabies disease. In the Americas rabies is endemic in many regions. All captive jaguars should be vaccinated against rabies using the killed vaccine (Imrab®, Pitman-Moore, Inc., Washington Crossing, NJ 08560). This (or any) rabies vaccine is NOT licensed for nondomestic species. However, the current compendium of animal rabies prevention and control, 2001 states "Zoos or research institutions may establish vaccination programs which attempt to protect

valuable animals, but these should not replace appropriate public health activities that protect humans.”

5. Canine Distemper Virus:

Canine distemper virus (CDV) has been reported in all families of terrestrial carnivores. Since 1991, CDV infections have been reported in five species of free-ranging and captive felids from at least eight discontiguous sites and epidemics in captive lions, tigers, leopards, and jaguars have been reported in the 1990s as reviewed in Deem *et al.*, 2000. The AZA Felid Taxon Advisory Group does not recommend vaccinating captive non-domestic felids at this time. However, the new canarypox-vectored CDV vaccine (PUREVAX®, Merial) has proven safe and effective in many nondomestic species. Some zoos are currently using this vaccine in jaguars and other non-domestic felids in the face of CDV epidemics.

6. Leptospirosis:

Leptospirosis, caused by a variety of *Leptospira interrogans* serotypes, is a potential problem in all mammals. There are many reports of significant morbidity and mortality in zoo collections. However, the disease does not appear to be a major problem in felid species. A killed vaccine (Leptoferm C-I®, Smith Kline Beecham, Chicago, IL 60675) is available and has been used in some captive situations during leptospirosis epidemics. Unfortunately, limitations to this vaccine are the lack of cross protection for one serotype when vaccinated with a different serotype and the short lived (2 – 3 months) immunity post-vaccination.

7. Feline Leukemia:

Feline leukemia virus is a major pathogen in domestic cats (associated with neoplastic and non-neoplastic disease) throughout the world. However, infection and resulting disease is rare in non-domestic felids. There is a killed vaccine (Leukocell®, Smith Kline Beecham, Chicago, IL 60675) available for use in domestic cats but it is NOT recommended for use in non-domestic felids at this time.

8. Feline Immunodeficiency Virus:

Feline immunodeficiency virus is an often fatal and serious disease of domestic cats. However there is no clear correlation between virus infection and disease in non-domestic felids. A new killed vaccine (Fel-O-Vax® FIV, Fort Dodge Lab Inc., Fort Dodge, IA 50501) is available for use in domestic cats but is NOT recommended for use in non-domestic felids at this time.

9. Feline Infectious Peritonitis:

Feline infectious peritonitis is a coronavirus that causes severe disease in both domestic and non-domestic cats. There is a commercial modified live virus vaccine marketed for domestic cats. Presently, this vaccine is NOT recommended for use in non-domestic felids due to questions about its safety and efficacy.

Parasite Control

Jaguars should be evaluated for ectoparasites whenever a physical examination is performed. Stool samples should be evaluated on a routine basis (4 X / year) for internal parasites. Endoparasites are relatively common and ubiquitous in captive situations. Some parasites may be acquired from the feed and not be pathogenic in jaguars. Pathogenic species commonly identified in jaguars are from the orders Ascarididae and Strongyloidea (i.e., *Toxocara*, *Toxascaris*, *Ancylostoma*). Coccidia can also be a problem in captive jaguars. Based on fecal results, anthelmintics should be administered to minimize the parasite load. These agents are often more effective when administered for more than one day (i.e., three consecutive days). Follow-up treatment to remove larval stages not susceptible during the initial treatment may also be required. Thorough daily cleaning and disinfection of enclosures will substantially lower the chance of reinfections.

Anthelmintics that have been effective and safe in jaguars include:

Carbaryl (0.5%) as a topical powder. For flea control.

Fenbendazole (Panacur[®], American Hoescht, Somerville, NJ 08876): 5-10 mg/kg p.o. Most commonly given as a single day treatment, but can be given for 3 consecutive days at this dose.

Ivermectin (Ivomec[®], Merck and Co., Rahway, NJ 07065): 0.2 mg/kg s.c. or p.o. Use as a single day treatment.

Praziquantel (Droncit[®], Haver-Lockhart, Shawnee, KS 66201): 5.5-6.6 mg/kg s.c. or p.o. For cestodes.

Pyrantel pamoate (Strongid[®], Pfizer Inc., New York, NY 10017): 3-5 mg/kg p.o. Can be given at this dose for 3-5 consecutive days.

Pyrethrins (0.15%) plus piperonyl butoxide (1.0%). For flea control.

Sulfadimethoxine (Albon[®], Roche Chemical Div., Nutley, NJ 07110): 50 mg/kg, s.c. or p.o. For coccidiosis.

Nutritional Needs

Jaguars, like all cat species, are obligate carnivores. Historically, nutritional related diseases (i.e., metabolic bone disease, amino acid deficiencies) have been a problem of captive non-domestic (and domestic) cats. There are less clinical nutritional diseases seen now as we have access to commercial diets that provide the proper nutrients. Obesity is one nutritional disease that is still commonly seen in captive jaguars. Additionally, hand-raised jaguar cubs are known to suffer from metabolic bone disease when not properly fed. For more information, refer to chapters on Nutrition and Hand Rearing.

Reproduction and Neonatal Care

Information on reproduction and mother reared neonatal cubs is provided in the chapter on Management of Reproduction. Hand rearing of cubs is sometimes attempted by zoos when mother rearing is not practical. Guidelines are provided in the Hand Rearing chapter.

MEDICAL CONCERNS OF CAPTIVE JAGUARS

Signs of Illness

Non-domestic felids may hide signs of illness until a disease is advanced. In captive settings, it is important that animal care staff be astute to subtle changes in behavior or physiologic signs that may suggest illness. Keepers that have daily contact with jaguars are often the best persons for noting these subtle changes. Any change in appetite, urination, defecation, or general behavior should be documented. For example, changes in urine and fecal color, quantity and consistency should be noted. Dehydration can be assessed by a visual examination that shows a jaguar with dry mucous membranes and a dry hair coat. Other visual observations that can be obtained from outside the enclosure include evaluation for normal breathing patterns and rate (N=8-24 bpm). Other physiologic parameters, such as temperature (N=37 – 39.5⁰ C or 98.6 – 103.1⁰ F) and pulse (N=70 – 140 bpm) require handling the animal.

Non-infectious Diseases Commonly Seen in Captivity

There are a number of diseases documented in the literature that occur in captive jaguars. Non-infectious diseases include a high incidence of neoplasia which may be associated with husbandry in captivity and/or longevity. Dental disease, including calculi and tooth fractures, is also commonly seen in captive jaguars. Laceration, with or without subsequent abscess formation, can also be a problem in captive jaguars. Kidney and musculoskeletal diseases occur in jaguars, as in other large cat species, especially as they age.

Infectious Agents Known to Infect and/or Cause Disease in Jaguars

Many infectious agents have been documented to cause morbidity and/or mortality in jaguars including protozoan (Cirillo *et al.*, 1990), bacterial (Abdulla *et al.*, 1982) and viral pathogens (i.e., canine distemper virus, feline infectious peritonitis) (Appel *et al.*, 1994; Fransen, 1973). Additionally, there is serologic evidence of infection with canine distemper and feline immunodeficiency virus (Appel *et al.*, 1994, Barr *et al.*, 1989; Brown *et al.*, 1993; Deem, 2001). It is also assumed that jaguars are susceptible to the common respiratory disease agents of domestic and non-domestic cats.

ADDITIONAL INFORMATION

Please submit published, anecdotal, and experimental findings related to jaguar health to the SSP veterinary advisor. Information gathered by health professionals working with jaguars is the key to expanding our knowledge on jaguar health and diseases. The SSP coordinator and veterinary advisor will work to disseminate these health related findings to AZA institutes that house jaguars.

REFERENCES

- Abdulla, P.K., P.C. James, S. Sulochana, V. Jayaprakasan, and R.M. Pillai. 1982 Anthrax in a jaguar (*Panthera onca*). *J Zoo An. Med.* 13: 151.
- Appel, M.J.G., R.A. Yates, G.L. Foley, J.J. Bernstein, S. Santinelli, L.H. Spelman, L.D. Miller, L.H. Arp, M. Anderson, M. Barr, S. Pearce-Kelling, and B.A. Summers. 1994. Canine distemper epizootic in lions, tigers, and leopards in North America. *J. Vet. Diagn. Invest.* 6: 277-288.
- Armstrong, D. 1990. Adverse reactions to Telazol[®] in tigers. *Tiger Beat.* 3: 11.
- Barr, M.C., P.P. Calle, M.E. Roelke, and F.W. Scott. 1989. Feline immunodeficiency virus infection in nondomestic felids. *J. Zoo Wildl. Med.* 20: 265-272.
- Brown, E.W., N. Yuhki, C. Packer, and S.J. O'Brien. 1993. Prevalence of exposure to feline immunodeficiency virus in exotic felid species. *J. Zoo Wildl. Med.* 24: 357-364.
- Cirillo, F., M. Ayala, and G. Barbato. 1990. Giardiasis and pancreatic dysfunction in a jaguar (*Panthera onca*): case report, evaluation, and comparative studies with other felines. In: *Proc. Am. Assoc. Zoo Vet.* South Padre Island, Texas. October 21 - 26. p 69-73.
- Conti, L., S. R. Jenkins, M. Auslander, R. H. Johnson, M. J. Leslie, and F. E. Sorhage. 2001. Compendium of animal rabies prevention and control. *J.A.V.M.A.* 218: 26-31.
- Deem, S.L., Spelman, L.H., Yates, R.A., and Montali, R.J. 2000. Canine distemper in terrestrial carnivores: a review. *J. Zoo Wildl. Med.* 31: 441-451.
- Deem, S.L. 2001. "Jaguar (*Panthera onca*) health evaluation results". Report submitted to the Wildlife Conservation Society and the Simon Bolivar Zoological Park, Costa Rica.
- Deem, S.L. 2002. Capture and immobilization of free-living jaguars (*Panthera onca*). In: *Zoological Restraint and Anesthesia*. D. Heard, ed., Ithaca: International Veterinary Information Service; B0183.0102.
- Deem, S.L., and Karesh, W.B. 2001. *The Jaguar Health Program Manual*. [http://www.savethejaguar.com/fieldvet health manual.pdf](http://www.savethejaguar.com/fieldvet%20health%20manual.pdf). p 1-45
- Fransen, D.R. 1972-1973. Feline infectious peritonitis in an infant jaguar. In: *Proc. Am. Assoc. Zoo Vet.* Houston, TX. 1972 and Columbus, OH. 1973. p 261-264.
- International Species Information System. 1999. *Medical animal record keeping system*. 12101. Johnny Cake Ridge Road, Apple Valley, Minnesota. <http://www.worldzoo.org>

Kreeger, T.J. 1996. Emergency Treatment – Animal. In: *Handbook of Wildlife Chemical Immobilization*. Laramie: Wildlife Veterinary Services, Incorporated. p 79-96.

Morrison, W.B., Starr, R.M., and the Vaccine-Associated Feline Sarcoma Task Force. 2001. Vaccine-associated feline sarcomas. *J.A.V.M.A.* 218: 697-702.

BIBLIOGRAPHY (VETERINARY RELATED PAPERS)

Capture/Immobilization/Anesthesia related:

Armstrong, D. 1990. Adverse reactions to Telazol® in tigers. *Tiger Beat*. 3: 11.

Bauditz, R. 1972. Sedation, immobilization and anesthesia with Rompun® in captive and free-living wild animals. *Vet. Med. Rev.* 3: 204-226.

Boever, W.J., J. Holden, K.K. Kane. 1977. Use of Telazol® (CI-744) for chemical restraint and anesthesia in wild and exotic carnivores. *Vet. Med./Sm. Ani. Clin., Exotic Species*, p 1722-1725.

Crawshaw, P. G. 1992. Recommendations for study design on research projects on neotropical felids. In: *Felinos de Venezuela – Biología, Ecología y Conservación*. Memorias del Simposio Organizado por Fudeci del 01 al 04 de Septiembre de 1991. FUDECI, Caracas. p 187-222.

Crawshaw, P.G. 2001. *Capture methods of large felids, with special reference to the jaguar (Panthera onca)*. <http://www.savethejaguar.org>

Deem, S.L. 2002. Capture and immobilization of free-living jaguars (*Panthera onca*). In: *Zoological Restraint and Anesthesia*. D. Heard ed. Ithaca: International Veterinary Information Service; B0183.0102.

Deem, S.L., and Karesh, W.B. 2001. *The Jaguar Health Program Manual*. http://www.savethejaguar.com/fieldvet_health_manual.pdf. p 1-45.

Evans, A.T. 1996. Anesthetic emergencies and accidents. In: *Lumb and Jones Veterinary Anesthesia*. 3rd Edition. J.C. Thurmon, W.J. Tranquilli, and G.J. Benson eds. Philadelphia: Wilkins and Wilkins Co. p 849-860.

Fowler, M.E. 1995. Medical problems during restraint. In: *Restraint and Handling of Wild and Domestic Animals*. 2nd Edition. Ames: Iowa State University Press. p 78-99.

Gray, C.W., M. Bush, and C.C. Beck. 1974. Clinical experience using CI-744 in chemical restraint and anesthesia of exotic specimens. *J. Zoo Ani Med.* 5: 12-21.

Hoogsteijn R., and E. Mondolfi. 1992. *The Jaguar*. Caracas: Armitano Publishers.

Hoogesteijn, R., R. McBride, M. Sunquist, A. Hoogesteijn, and L. Farrell. 1996. Medetomidine and rubber-padded leg-hold traps in Venezuelan cat studies. Salinas: International Wildlife Veterinary Services, Inc., 1991. Wildlife Restraint Series. *Cat News* 25: 22-23

Jalanka, H.H., and B.O. Roeken. 1990. The use of medetomidine, medetomidine-ketamine combinations, and atipamezole in nondomestic animals: a review. *J. Zoo Wildl. Med.* 21: 259-282.

Kreeger, T.J. 1996. *Handbook of Wildlife Chemical Immobilization*. Laramie: International Wildlife Veterinary Services, Inc. p 175

Kreeger, T.J. 1996. Emergency treatment - Animal. In: *Handbook of Wildlife Chemical Immobilization*. Laramie: International Wildlife Veterinary Services, Inc. p 79-96.

Lopez de Buen, L., J. M. Aranda Sanchez. 1986. Nota zoologica. Anestesia de mamiferos silvestres con la combinacion ketamina-xilacina. *Biotica*. p 67-71.

Morato, R.G., C.A. Moura, and P.G. Crawshaw. 2002. Inmovilizacion quimica de jaguars libres con una combinacion de teletamina y zolazepam. In: *El jaguar en el nuevo milenio*. R.A. Medellin, C. Equihua, C.L.B. Chetkiewicz, P.G. Crawshaw, A. Rabinowitz, K.H. Redford, J.G. Robinson, E.W. Sanderson, and A.B. Taber compiladores. p 91-99.

Nielsen, L. 1999. *Chemical Immobilization of Wild and Exotic Animals*. Ames: Iowa State University Press. p 342.

Nielsen, L. 1999. Management of medical emergencies in the field. In: *Chemical Immobilization of Wild and Exotic Animals*. Ames: Iowa State University Press. p 209-226.

Seal, U.S., and T.J. Keeger. 1987. Chemical immobilization of furbearers. In: *Wild Furbearer Management and Conservation in North America*. M. Novak *et al.*, eds. Toronto: Ministry of Natural Resources. p 191-215.

Shobert, E. 1987. Telazol use in wild and exotic animals. *Vet. Med.* 82: 1080-1088.

General anatomy, genetics, physiology, reproduction:

Amato, G., and C. Lehn. 2002. *Manual for the collection, storage, and transportation of biomaterials for genetic studies on jaguars (Panthera onca)*. <http://www.savethejaguar.org>

Gonçalves, R., M.A.de B.V. Guimaraes, A.L.V. Nunes, A. C. Carciofi, F. Ferreira, V.H. Barnabe, and R.C. Barnabe. 1998. Colheita e avaliacao do sêmen em onca pintada (*Panthera onca*). *Braz. J. Vet. Res. Anim. Sci.* 35: 178-181.

Hawkey, C.M., and M.G. Hart. 1986. Haematological reference values for adult pumas, lions,

tigers, leopards, jaguars and cheetahs. *Res. Vet. Sci.* 41: 268-269.

International Species Information System. 1999. *Medical animal record keeping system*. 12101. Johnny Cake Ridge Road, Apple Valley, Minnesota. <http://www.worldzoo.org>

Morato, R.G., and R.C. Barnabe. 2002. Potencial de técnicas reproductivas para la conservación de jaguar. In: *El jaguar en el nuevo milenio*. R.A. Medellín, C. Equihua, C.L.B. Chetkiewicz, P.G. Crawshaw, A. Rabinowitz, K.H. Redford, J.G. Robinson, E.W. Sanderson, and A.B. Taber compiladores p 43-53.

Morato, R.G., and R.C.R. Paz. 2001. Reproduction in jaguars. In: *Biology, Medicine, and Surgery of South American Wild Animals*. M.E. Fowler, and Z.S. Cubas eds. Ames: Iowa State University Press. p 308-312.

Morato, R.G., de Vaz Guimaraes, M.A.B., Ferreira, F., Verreschi, I.T. do N., and Barnabe, R. C. 1999. Reproductive characteristics of captive male jaguars (*Panthera onca*). *Brazilian J. Vet. Res. Anim. Sci.* 36: 1-10.

Swanson, W.F., D.E. Wildt, R.C. Cambre, S.B. Citino, K.B. Quigley, MVZ D. Brousset, R.N. de Morais, N. Moreira, S.J. O'Brien, and W.E. Johnson. 1995. Reproductive survey of endemic felid species in Latin American zoos: male reproductive status and implications for conservation. In: *Proc. Am. Assoc. Zoo Vet. / Wildl. Dis. Asso. / Am. Assoc. Wildl. Vet.* East Lansing, Michigan. August 12-17. p 372-380.

Non-Infectious Diseases

Bossart, G.D., and G. Hubbell. 1983. Ovarian papillary cystadenocarcinoma in a jaguar (*Panther onca*). *J. Zoo An. Med.* 14: 73-76.

Deem, S.L., and Karesh, W.B. The veterinarian's role in species-based conservation: the jaguar (*Panthera onca*) as an example. In: *Proceedings of the American Association of Zoo Veterinarians*. Milwaukee, Wisconsin, October 6-10, 2002. p 1-5.

Frazier, K.S., M.E. Hines, C. Ruiz, A.J. Herron, and N.H. Altman. 1994. Immunohistochemical differentiation of multiple metastatic neoplasia in a jaguar (*Panther onca*). *J. Zoo Wildl. Med.* 25: 286-293.

Ialeggio, D.M., and D. J. Brockman. 1995. Gastric dilatation-volvulus and belt-loop gastropexy in a jaguar (*Panthera onca*). In: *Proc. Am. Assoc. Zoo Vet. / Wildl. Dis. Asso. / Am. Assoc. Wildl. Vet.* East Lansing, Michigan. August 12-17. p 345.

Karesh, W.B., and G. Bottomley. 1983. Vaccine induced anaphylaxis in a Brazilian jaguar (*Panthera onca plaustrix*). *J. Zoo An. Med.* 14: 133-137.

Kollias, G.V., M.B. Calderwood-Maybs, B.G. Short. 1984. Diabetes mellitus and abdominal adenocarcinoma in a jaguar receiving megestrol acetate. *J.A.V.M.A.* 11: 1383-1386.

Ladiges, W.C., J.W. Foster, and M.H. Jones. 1981. Malignant hemangioendothelioma in a jaguar (*Panthera onca*). *J. Zoo An. Med.* 12: 36-37.

Lenhard, A., and M.E. Pequet Goad. 1985. A case of pancreatic adenocarcinoma in the jaguar. In: *Proc. Am. Assoc. Zoo Vet.* Scottsdale, Arizona. October 5-10. p 67-68.

McLaughlin, R., and A. Kuzma. 1991. Surgical management of collapsed pelvis in a jaguar. *J.A.V.M.A.* 198: 1789-1791.

Port, C.D., E.R. Maschgan, J. Pond, and D.G. Scarpelli. 1981. Multiple neoplasia in a jaguar (*Panthera onca*). *J. Comp. Path.* 91: 115-122.

Ramos-Vara, J.A., M.A. Miller, and D. Preziosi. 2000. Glucagonoma in a jaguar (*Panthera onca*). *J. Zoo. Wildl. Med.* 31: 563-656.

Snyder, S.B., and M.J. Richard. 1984. Apparent familial hypothyroidism in jaguars (*Panthera onca*). In: *Proc. Am. Assoc. Zoo Vet.* p 132-133.

Infectious/Parasitic Diseases

Abdulla, P.K., P.C. James, S. Sulochana, V. Jayaprakasan, and R.M. Pillai. 1982. Anthrax in a jaguar (*Panthera onca*). *J. Zoo An. Med.* 13: 151.

Aguilar, R.F., Grooters, A.M, Camus, A., and Garner, M.M. 2002. Pulmonary pythiosis in a Central American jaguar (*Panthera onca*). In: *Proceedings of the American Association of Zoo Veterinarians.* Milwaukee, Wisconsin, October 6-10 p 150-153.

Appel, M.J.G., R.A. Yates, G.L. Foley, J.J. Bernstein, S. Santinelli, L.H. Spelman, L.D. Miller, L.H. Arp, M. Anderson, M. Barr, S. Pearce-Kelling, and B.A. Summers. 1994. Canine distemper epizootic in lions, tigers, and leopards in North America. *J. Vet. Diagn. Invest.* 6: 277-288.

Barr, M.C., P.P. Calle, M.E. Roelke, and F.W. Scott. 1989. Feline immunodeficiency virus infection in nondomestic felids. *J. Zoo Wildl. Med.* 20: 265-272.

Brown, E.W., N. Yuhki, C. Packer, and S.J. O'Brien. 1993. Prevalence of exposure to feline immunodeficiency virus in exotic felid species. *J. Zoo Wildl. Med.* 24: 357-364.

Choi, J.H., H.S. Yoo, J.Y. Park, Y.K. Kim, E. Kim, and D.Y. Kim. 2002. Morganeliasis pneumonia in a captive jaguar. *J. Wildl. Dis.* 38(1) 199-201.

Cirillo, F., M. Ayala, G. Barbato. 1990. Giardiasis and pancreatic dysfunction in a jaguar (*Panthera onca*): case report, evaluation, and comparative studies with other felines. In: *Proc. Am. Assoc. Zoo Vet.* South Padre Island, Texas, October 21 - 26. p 69-73.

Deem, S.L. 2001. "Jaguar (*Panthera onca*) health evaluation results." Report submitted to the Wildlife Conservation Society and the Simon Bolivar Zoological Park, Costa Rica.

Fransen, D.R. 1972-1973. Feline infectious peritonitis in an infant jaguar. In: Proc. *Am. Assoc. Zoo Vet.* Houston, TX, 1972 and Columbus, OH, 1973. p 261-264.

Hoogesteijn R., and E. Mondolfi. 1992. The Jaguar. Caracas: Armitano Publishers.

Patton, S., A. Rabinowitz, S. Randolph, and S. Strawbridge. 1986. A coprological survey of parasites of wild neotropical felidae. *J. Parasit.* 72: 517-520

General Bibliography

Almeida, A. de. 1974. *Jaguar hunting in the Mato Grosso and Bolivia*. Long Beach: Woodbine-Safari Press. 1990.

Brown, D. E., and C. A. Lopez Gonzales. 2001. *Borderland Jaguars*. Salt Lake City: University of Utah Press.

Carmony, N. B. 1989. *Onza !: The hunt for a legendary cat*. Silver City: High-Lonesome Books. 1995.

Eisenberg J. F. 1989. *Mammals of the neotropics: The northern neotropics*. Volume 1. Chicago: The University of Chicago Press.

Guggisberg, C. 1975. *Wild Cats of the World*. New York: Taplinger Press.

Hall, E. R., and W. W. Dalquest. 1963. *The mammals of Veracruz*. University of Kansas: Museum of Natural History Publication. p 165-362.

Hoogesteijn, R., and E. Mondolfi. 1992. *The Jaguar*. Caracas: Armitano Publishers.

Nowell, K., and P. Jackson. 1996. *IUCN Wild Cats: Status Survey and Conservation Action Plan*. Gland: IUCN.

Perry, R. 1970. *The World of the Jaguar*. Newton Abbot: David and Charles Ltd.

Quigley, H. B. 1987. *Ecology and Conservation of the Jaguar in the Pantanal Region, Mato Grosso do Sul, Brazil*. Moscow: Ph.D. dissertation. University of Idaho, Moscow.

Rabinowitz, A. 1986. *Jaguar*. New York: Arbor House.

Watt, E. M. 1989. *Jaguar Women*. Toronto: Key Porter Books.

(For more resources on the jaguar we recommend *An Extensive Bibliography on the Jaguar* published by E. Lee Fitzhugh which includes over 866 citations. For a disk copy of the entire bibliography please e-mail Robert Wiese at bob@fortworthzoo.org and indicate MS WORD or WordPerfect format).

Acknowledgement and thanks go out to all those who contributed to this work. The Jaguar Species Survival Plan is indebted to them for written chapters, financial and development support, and time spent on review, editing and comments.

Christopher Law, Editor, Philadelphia Zoo; telephone: (215) 243-5316,
e-mail: chris_law@prodigy.net

William K. Baker, Jr., Little Rock Zoo; telephone: (501) 666-2406 x102,
e-mail: puma_cat@hotmail.com

Sharon Deem DVM, National Zoological Park; telephone: (202) 673-7980,
e-mail: deems@nmpz.si.edu

Amy Hunt, MS, Fort Worth Zoo; telephone: (817) 759-7145; ahunt@fortworthzoo.org

Linda Munson DVM, University of California; telephone: (530) 754-7567,
e-mail: lmunson@ucdavis.edu

Stacey Johnson, Fort Worth Zoo; telephone (817) 759-7190; e-mail: sjohnson@fortworthzoo.org

Rebecca Spindler, Ph.D., National Zoological Park; telephone: (540) 635-6594
e-mail: rspindler@crc.si.edu

Ann Ward, MS, Fort Worth Zoo; telephone: (817) 759-7141; e-mail: award@fortworthzoo.org

Formatted

Dominic Calderisi, Lincoln Park Zoo
Stephanie Crowson, Fort Worth Zoo
Brent Day, Little Rock Zoo
Marie Greene, Little Rock Zoo
Stacey Johnson, Fort Worth Zoo
Gray Lang, Dallas World Aquarium
Gwen Lovett, Palm Beach Zoo
Keith Lovett, Palm Beach Zoo
Stephanie Lubianski, Houston Zoo

Danny Morris, Omaha's Henry Doorly Zoo
Jim Schnormeier, Sacramento Zoo
Alan Shoemaker, Columbia, SC
Rebecca Spindler, National Zoo
Becky Volk, Fort Worth Zoo
Chris Waldron, Philadelphia Zoo
John Ward, Fort Worth Zoo
Diana Weinhardt, Houston Zoo
Robert Wiese, Fort Worth Zoo

Patti Hainley, Panthera Research
Debbie Thompson, Little Rock Zoo